

DEPARTMENT OF THE ARMY TECHNICAL BULLETIN

SHOP EQUIPMENT, AUTOMOTIVE MAINTENANCE AND REPAIR,
FIELD MAINTENANCE BASIC
(NSN 4910-00-754-0705),
INSTALLATION IN
ONE M109A3 SHOP VAN TRUCK,
TWO M35A2 CARGO TRUCKS,
AND
THREE M105A2 CARGO TRAILERS

This copy is a reprint which includes current
pages from Change 1.

Approved for public release; distribution is unlimited

CHANGE)
)
No. 1)

HEADQUARTERS
DEPARTMENT OF THE ARMY
Washington, DC, 23 December 1987

SHOP EQUIPMENT, AUTOMOTIVE MAINTENANCE AND REPAIR,
FIELD MAINTENANCE BASIC
(NSN 4910-00-754-0705)
INSTALLATION IN ONE M109A3 SHOP VAN TRUCK,
TWO M35A2 CARGO TRUCKS,
AND
THREE M105A2 CARGO TRAILERS

TB 9-4910-744-30, 17 April 1987, is changed as follows:

1. Remove old pages and insert new pages as indicated below. New or changed material is indicated by a vertical bar to the left of the changed material. Changed illustrations are indicated by a miniature pointing hand highlighting the general area of the change.

Remove Pages

61 through 64
69 and 70

Insert Pages

61 through 64
69 and 70

2. File this change sheet in back of the publication for reference purposes.

By Order of the Secretary of the Army:

CARL E. VUONO
General, United States Army
Chief of Staff

Official:

R. L. DILWORTH
Brigadier General, United States Army
The Adjutant General

DISTRIBUTION:

To be distributed in accordance with DA Form 12-21, requirements for
FSC 4910: Motor Vehicle, Repair Shop Specialized Equipment.

☆US GOVERNMENT PRINTING OFFICE : 1990 O - 261-872 (20679)

TECHNICAL BULLETIN)
No.9-4910-744-30*)

HEADQUARTERS
DEPARTMENT OF THE ARMY
Washington, DC, 17 April 1987

SHOP EQUIPMENT, AUTOMOTIVE MAINTENANCE AND REPAIR

FIELD MAINTENANCE BASIC

(NSN4910-00-754-0705),

INSTALLATION IN

ONE M109A3 SHOP VAN TRUCK,

TWO M35A2 CARGO TRUCKS,

AND

THREE M105A2 CARGO TRAILERS

Approved for public release; distribution is unlimited

Reporting Errors and Recommending Improvements

You can help improve this bulletin. If you find any mistakes or if you know of a way to improve the procedures, please let us know. Mail your letter or DA Form 2028 (Recommended Changes to Publications and Blank Forms) direct to: Commander, US Army Armament, Munitions and Chemical Command, ATTN: AMSMC-MAS(R), Rock Island, IL 61299-6000. A reply will be furnished to you.

TABLE OF CONTENTS

Para		Page
1	GENERAL	1
2	WARNINGS AND CAUTIONS	1
3	LOCATION OF EQUIPMENT	1
4	INSTALLATION	12

LIST OF ILLUSTRATIONS

Figure	Title	Page
	M109A3 shop van truck, unit 1	23
1	Components to be mounted, unit 1, M109A3, floor plan	24
3	Components to be mounted, unit 1, M109A3, left side elevation	25

*This bulletin supersedes TB ORD 4900-30/3, dated 9 September 1958.

LIST OF ILLUSTRATIONS--Continued

Figure	Title	Page
4	Components to be mounted, unit 1, M109A3, right side elevation	26
5	Location of strap loops, front wall, unit 1, M109A3	27
6	M35A2 cargo truck, units 2 and 3	28
7	Components to be mounted, unit 2, M35A2, floor plan	29
8	Components to be mounted, unit 2, M35A2, right side elevation	30
9	Components to be mounted, unit 2, M35A2, left side elevation	31
10	Hole dimensions for mounting holes and strap loops, unit 2, M35A2, floor plan	32
11	Hole dimensions and locations for blind rivet nuts and strap loops in left side wall, unit 2, M35A2	33
12	Hole dimensions for blind rivet nuts and strap loops in front wall, unit 2, M35A2	34
13	Hole dimensions for cabinet top strap loops, unit 2, M35A2	35
14	Hole dimensions for blind rivet nuts, unit 2, M35A2, cabinet side	36
15	Components to be mounted, unit 3, M35A2, floor plan	37
16	Components to be mounted, unit 3, M35A2, right side elevation	38
17	Components to be mounted, unit 3, M35A2, left side elevation	39
18	Hole dimensions for mounting holes and strap loops, unit 3, M35A2, floor plan	40
19	Hole dimensions and locations for blind rivet nuts and strap loops, unit 3, M35A2, front wall	41
20	Hole dimensions and locations for blind rivet nuts and strap loops, unit 3, M35A2, left side wall	42
21	Hole dimensions for blind rivets, unit 3, M35A2, cabinet side	43
22	M105A2 cargo trailer, units 4, 5, and 6	44
23	Components to be mounted, unit 4, M105A2, floor plan	45
24	Components to be mounted, unit 4, M105A2, right side elevation	46
25	Components to be mounted, unit 4, M105A2, left side elevation	47
26	Hole dimensions for mounting holes and strap loop, unit 4, M105A2, floor plan	48
27	Hole dimensions for blind rivet nuts and strap loops in right side wall, unit 4, M105A2	49
28	Hole dimensions for blind rivet nuts and strap loops in left side wall, unit 4, M105A2	50
29	Components to be mounted, unit 5, M105A2, floor plan	51
30	Components to be mounted, unit 5, M105A2, right side elevation	52
31	Components to be mounted, unit 5, M105A2, left side elevation	53
32	Hole dimensions for mounting holes, unit 5, M105A2, floor plan	54
33	Hole dimensions for blind rivet nuts and strap loops, unit 5, M105A2, left side wall	55

LIST OF ILLUSTRATIONS--Continued

Figure	Title	Page
34	Hole dimensions for blind rivet nuts and strap loops, unit 5, M105A2, right side wall	56
35	Components to be mounted, unit 6, M105A2, floor plan	57
36	Hole dimensions for mounting holes and strap loops, unit 6, M105A2, floor plan	58
37	Hole dimensions for blind rivet nuts and strap loops, unit 6, M105A2, right side elevation	59
38	Hole dimensions for blind rivet nuts and strap loops, unit 6, M105A2, left side elevation	60
39	Retaining strap locations for mounting 20-ft hoses, unit 6, M105A2, front elevation	61
40	Electrical components to be mounted, units 2 and 3, M35A2, top view	62
41	Electrical components to be mounted, units 2 and 3, M35A2, right side elevation	63
42	Electrical components to be mounted, units 2 and 3, M35A2, left side elevation	64
43	Electrical schematic, units 2 and 3, M35A2	65
44	Power cable assembly, 11021163, units 2 and 3, M35A2	66
45	Power cable assembly, 11021164, units 2 and 3, M35A2	67
46	Power cable assembly, 11021165, units 2 and 3, M35A2	68
47	Power cable assembly, 11021166, units 2 and 3, M35A2	69

1. General

a. Instructions contained in this bulletin are to be used as a guide for installation of field maintenance basic automotive maintenance and repair shop equipment (NSN 4910-00-754-0705) in one M109A3 shop van truck, two M35A2 cargo trucks, and three M105A2 cargo trailers.

b. Slight variations to the installation instructions may be made at the discretion of the officer in charge.

c. Complete lists of items contained in this shop are found in SC 4910-95-CL-A31.

d. Personnel performing this installation should have a practical knowledge of electricity.

e. Items not mentioned in this bulletin, that may be components of this shop, may be stowed in storage cabinets and drawers or secured in such a manner as to avoid damage in transit.

f. All dimensions, fastener sizes, and hardware sizes are in inches.

g. When entering the shop, curbside is at right and roadside is at left.

2. Warnings and Cautions

WARNING

All electrically powered tools and equipment must be grounded prior to use.

Extinguish all smoking materials and do not permit an open flame or sparks in the vicinity of flammable gases or liquids.

Drill bits can fracture or break during use. Wear safety glasses at all times when drilling holes.

CAUTION

Special care should be exercised to avoid damage to electrical connectors, wiring, or electrical equipment.

To preserve its waterproof characteristics, precautions should be taken not to puncture the outer skin when drilling holes into the walls of the shop. Coat underside of vehicle body with coating compound (UNDER-COATING TT-C-520, NSN 8030-00-221-1834) where mounting hardware projects through floor.

3. Location of Equipment

a. Location of equipment installed or stowed in units 1 thru 6 is referenced in figures 1 thru 39.

(1) Refer to table 1 for hardware required for installation.

(2) Refer to table 2 for components to be mounted.

(3) Refer to table 3 for electrical components to be mounted.

b. Refer to table 4 for standard conversion chart.

3. Location of Equipment--Continued

Table 1. Mounting Hardware

MS/part no.	Size and description	Qty	Application
MS3367-3-0	12.00-in. Tiedown Strap	56	Power cable assemblies
MS16992-521	5/16-in. Hex Head Lag Bolt X 1-1/4 L	28	72-in. tables w/drawers, 60-in. tables
MS20601-MP6W2	3/16-in. Blind Rivet	2	Strap loop
A10-180	#10-32 UNF Blind Rivet Nut	172	Installation of strap loops on vehicle walls and floor.
MS27183-11	5/16-in. Flat Washer	6	Drill stand, utility grinder
MS27183-12	11/32-in. Flat Washer	32	72-in. tables
MS27183-13	3/8-in. Flat Washer	16	Storage cabinets, hose assembler
MS27183-15	7/16-in. Flat Washer	8	Arbor press, brake drum lathe
MS27183-17	1/2-in. Flat Washer	10	3-in. and 4-in. machinist's vises, valve face grinding machine
MS27183-18	17/32-in. Flat Washer	8	3-in. and 4-in. machinist's vises
MS27183-42	7/32-in. Flat Washer	32	Installation of strap loops
MS35191-276	#10-32 UNF Counter Head Machine Screw x 1.00 in. L	228	Installation of strap loops
MS35190-276	#10-24 UNC-2A Counter-sunk Head Machine Screw x 1-1/4 L	32	Installation of strap loops
MS35338-43	#10 Lockwasher	68	Installation of strap loops

3. Location of Equipment--Continued

Table 1. Mounting Hardware--Continued

MS/part no.	Size and description	Qty	Application
MS35338-44	1/4-in. Lockwasher	4	Separators
MS35338-45	5/16-in. Lockwasher	58	72-in. tables w/drawers, 60-in. tables, utility grinder, drill stand, steam cleaner, 72-in. tables
MS35338-46	3/8-in. Lockwasher	28	Storage cabinets, hose assembler, gas engine generator set, tire spreader
MS35338-47	7/16-in. Lockwasher	28	Arbor press, bows--electrical installation, brake drum lathe
MS35338-48	1/2-in. Lockwasher	30	Compressors, diesel engine generator set, valve face grinding machine, 3-in. and 4-in. machinist's vises
MS35492-78	#10 Flat Head Wood Screw x 1 L	4	Strap loops
MS35495-125	#14 Round Head Wood Screw x 7/8 L	4	Separators
MS35650-302	#10-32 UNF Hex Nut	68	Installation of strap loops
MS51861-49	#10 Tapping Screw x 1 L	32	Installation of duplex and lamp-holder junction boxes
MS51861-69	1/4-in. Tapping Screw x 1 L	8	Switch box--electrical surface mounted
MS51939-3	Strap Loop	145	For stowed item retention

3. Location of Equipment--Continued

Table 1. Mounting Hardware--Continued

MS/part no.	Size and description	Qty	Application
MS51967-5	5/16-18 UNC-2B Hex Nut	22	Drill stand, utility grinder, 72-in. tables
MS51967-8	3/8-16 UNC-2B Hex Nut	24	Storage cabinets, hose assembler, gas engine generator set, tire spreader
MS51967-11	7/16-14 UNC-2B Hex Plain Nut	28	Arbor press, brake drum lathe, bows--electrical installation
MS51967-14	1/2-13 UNC-2B Hex Nut	30	Compressors, diesel engine generator set, valve face grinding machine, 3-in. and 4-in. machinist's vises
MS51972-2	5/16-24 UNF-2B Hex Plain Nut	8	Steam cleaner
MS90725-36	5/16-18 UNC-2A Hex Head Capscrew x 1-1/4 L	16	72-in. tables
MS90725-43	5/16-18 UNC-2A Hex Head Capscrew x 2-3/4 L	6	Drill stand, utility grinder
MS90725-61	3/8-16 UNC-2A Hex Head Capscrew x 1-1/8 L	12	Storage cabinets
MS90725-63	3/8-16 UNC-2A Hex Head Capscrew x 1-3/8 L	4	Tire spreader
MS90725-67	3/8-16 UNC-2A Hex Head Capscrew x 2-1/4 L	8	Hose assembler, gas engine generator set
MS90725-87	7/16-14 UNC-2A Hex Head Capscrew x 1-1/4 L	4	Brake drum lathe
MS90725-88	7/16-14 UNC-2A Hex Head Capscrew x 1-3/8 L	24	Arbor press, bows--electrical installation

3. Location of Equipment--Continued

Table 1. Mounting Hardware--Continued

MS/part no.	Size and description	Qty	Application
MS90725-113	1/2-13 UNC-2A Hex Head Capscrew x 1-1/2 L	4	Diesel engine generator set
MS90725-115	1/2-13 UNC-2A Hex Head Capscrew x 2 L	8	Compressors
MS90725-120	1/2-13 UNC-2A Hex Head Capscrew x 3-1/4 L	18	Valve face grinding machine, 3-in. and 4-in. machinist's vises
8875T37	5/16-24 UNF-2A U-Bolt	4	Steam cleaner
7550588-7	92.00-in. Retaining Strap	4	Oxygen and acetylene cylinders, hand truck, mechanic's creepers
7550588-9	66.00-in. Retaining Strap	4	Dolly-type jack, ground rods, drain pans
7550588-3	48.00-in. Retaining Strap	16	Engine transport stands; oil bucket pumps; tool box; 12-ton hand hydraulic jacks; lubricating units; 1.25-in. od, 1.00-in. od, 1.75-in. od, 1.56-in. od, and 0.84-in. od hoses; grease bucket pumps
7550588-4	36.00-in. Retaining Strap	15	Hoisting unit, oxygen cylinders, dolly-type jack, transmission and differential lift, trestles, 8-ton hand hydraulic jack, engine transport stands

3. Location of Equipment--Continued

Table 1. Mounting Hardware--Continued

MS/part no.	Size and description	Qty	Application
7550588-5	24.00-in. Retaining Strap	14	2.00-in. od, 2.31-in. od, and 2.75-in. od hoses; motor vehicle engine and transmission sling; disk sander; 20-ft extension lights; 7-ft power cable assemblies; 4-qt liquid measure
7550588-7	92.00-in. Retaining Strap	4	Transmission and differential lift, mechanic's creepers
7550588-8	30.00-in. Retaining Strap	2	0.66-in. od hose, mechanic's creeper
7550588-9	66.00-in. Retaining Strap	5	Mechanic's creepers, welding rod rack, tool boxes
7550588-10	110.00-in. Retaining strap	6	Tool box, trestles, generator test set, wash pans, degreaser

Table 2. Components to be Mounted

NSN	Qty	Description	Figure no.
4910-01-015-7667	1	BEAD BREAKER, PNEUMATIC	3
7125-00-330-0130	6	CABINET, STORAGE: n-drawer	7-9-15-17
4910-00-725-9558	5	CABLE ASSEMBLY, POWER, ELECTRICAL: 3 condct, 25 ft	4
6150-00-682-3460	3	CABLE ASSEMBLY, POWER, ELECTRICAL: 3 condct, 50 ft	4
4910-00-800-1405	3	CABLE ASSEMBLY, POWER, ELECTRICAL: 4 condct, 7 ft	4-15-16

3. Location of Equipment--Continued

Table 2. Components to be Mounted--Continued

NSN	Qty	Description	Figure no.
2590-00-148-7961	1	CABLE KIT, SPECIAL PURPOSE	4
7240-00-499-8028	2	CAN, RADIATOR FILLING: 3-gal. cap. w/spout	3
4940-00-186-0027	1	CLEANER, STEAM, SKID MOUNTED	29 thru 31
3460-01-109-7664	2	COLLET SET MACHINE	4
4310-00-542-4566	2	COMPRESSOR, RECIPROCATING, POWER DRIVEN: 15 cfm, 175 psi	23-24-29-30
4910-00-251-6981	15	CREEPER, MECHANIC'S	2-5-7-9-15-16-35-37
8120-00-268-3360	1	CYLINDER, COMPRESSED GAS: acetylene	15
8120-00-151-9758	4	CYLINDER, COMPRESSED GAS: oxygen	15
4940-00-449-6689	1	DEGREASER	15-17
5130-00-473-6228	4	DRILL, ELECTRIC, PORTABLE: 3/4 in., morse tpr socket	3
5130-00-203-7943	1	ETCHER, ELECTRIC	3
4240-00-202-9473	1	FACESHIELD, INDUSTRIAL	3
4910-00-273-3658	1	FILLER AND BLEEDER, HYDRAULIC SYSTEM	3
6115-00-465-1044	1	GENERATOR SET, DIESEL ENGINE: 5 kw, 60 Hz, 120/240 V ac	23
6115-00-017-8236	1	GENERATOR SET, GASOLINE ENGINE: 1.5 kw, 28 V	35
4910-00-473-6437	1	GRINDING KIT, VALVE SEAT, ELECTRIC	4
4910-00-060-9983	1	GRINDING KIT, VALVE SEAT, ELECTRIC: 35-deg angle	4
3415-00-517-7754	1	GRINDING MACHINE, UTILITY	2-4

3. Location of Equipment--Continued

Table 2. Components to be Mounted--Continued

NSN	Qty	Description	Figure no.
4910-00-540-4679	1	GRINDING MACHINE, VALVE FACE	2-4
4910-00-448-0254	1	HOISTING UNIT, AUTOMOTIVE MAINTENANCE	15-16
4940-01-080-4213	1	HOSE ASSEMBLY OUTFIT consisting of:	4
4940-01-091-5099	1	HOSE ASSEMBLER: 5 hp, 115 V ac, w/14-ft cord	2-4
4720-01-017-5127	60 ft	HOSE, NONMETALLIC: 0.66-in. od	35-38
4720-00-289-2615	100 ft	HOSE, NONMETALLIC: 0.84-in. od	35-38
4720-01-018-6550	100 ft	HOSE, NONMETALLIC: 1.00-in. od	35-37
4720-00-080-3085	100 ft	HOSE, NONMETALLIC: 1.25-in. od	35-37
4720-00-893-5017	20 ft	HOSE, NONMETALLIC: 1.75-in. od	35-38
4720-00-289-2618	60 ft	HOSE, NONMETALLIC: 1.56-in. od	35-38
4720-00-432-7204	20 ft	HOSE, NONMETALLIC: 2.00-in. od	35-39
4720-01-075-2106	20 ft	HOSE, NONMETALLIC: 2.31-in. od	35-39
4720-00-926-1083	10 ft	HOSE, NONMETALLIC: 2.75-in. od	35
4910-00-289-7233	2	JACK, DOLLY TYPE, HYDRAULIC: 10-ton cap.	7-8-15
5120-00-595-8396	2	JACK, HYDRAULIC, HAND: 8-ton cap.	15-16
5120-00-224-7330	2	JACK, HYDRAULIC, HAND: 12-ton cap.	7-8
5120-00-188-1790	1	JACK, HYDRAULIC, HAND: 30-ton cap.	3
4910-01-028-9849	1	LATHE, BRAKE DRUM	7-8
4910-00-585-3622	2	LIFT, TRANSMISSION AND DIFFERENTIAL	7-8-15-16
6230-00-268-9436	6	LIGHT, EXTENSION: 20 ft, w/btry clips	15-16

3. Location of Equipment--Continued

Table 2. Components to be Mounted--Continued

NSN	Qty	Description	Figure no.
6230-00-729-9259	6	LIGHT, EXTENSION: 24 ft, plastic hdl	4
4930-00-720-4849	2	LUBRICATING UNIT, POWER OPERATED	23-25-29-31
7240-00-889-3765	2	MEASURE, LIQUID: 1-liter cap.	3
7240-00-255-8113	2	MEASURE, LIQUID: 2-qt cap., w/flex. spout	3
7240-00-233-6015	1	MEASURE, LIQUID: 4-qt cap., w/flex. spout	23-24
7240-00-255-5996	2	MEASURE, LIQUID: 8-qt cap., stl, w/flex. spout	3
4910-00-387-9592	2	PAN, DRAIN	7-8
4940-00-795-3595	10	PAN, WASH	7-9
3444-00-449-7295	1	PRESS, ARBOR, HAND OPERATED: hydr, floor type	7-8
4930-00-244-4859	2	PUMP, BUCKET, LUBRICATING GREASE	29-30
4930-00-244-4860	2	PUMP, BUCKET, LUBRICATING OIL	23-24
3439-00-564-5793	1	RACK, METAL, WELDING ROD	35-38
5975-00-777-6781	3	ROD, GROUND	7
5130-00-857-8526	1	SANDER, DISK, ELECTRIC, PORTABLE	15-16
4940-00-242-4101	2	SEPARATOR, OIL AND WATER, SPRAY GUN	23-24-29-30
4910-00-944-4915	1	SLING, ENGINE AND TRANSMISSION, MOTOR VEHICLE	23-25
4910-00-725-0326	1	SPREADER, TIRE	35-37
5130-00-263-8657	1	STAND, PORTABLE DRILL, VERTICAL	2-3
4910-00-338-6673	2	STAND, TRANSPORT, ENGINE	7-9

3. Location of Equipment--Continued

Table 2. Components to be Mounted--Continued

NSN	Qty	Description	Figure no.
4910-00-543-7772	2	TABLE, WORK, AUTCMOTIVE MAINTENANCE: 60 in. lg, w/shelves	2-3-4
4910-00-357-5342	2	TABLE, WORK, AUTOMOTIVE MAINTENANCE: 72 in. lg	15
4910-00-543-7771	2	TABLE, WORK, AUTOMOTIVE MAINTENANCE: 72 in. lg, w/drawers	2-3-4
4910-00-092-9136	1	TEST SET, GENERATOR	7-9
5140-00-315-2758	4	TOOL BOX, PORTABLE	23-35- 37-38
4910-00-251-8013	12	TRESTLE, MOTOR VEHICLE MAINTENANCE: 7-ton cap.	2-3-4- 7-8-15- 17
3920-01-113-0117	1	TRUCK, HAND, TWO-WHEELED	15-17
3460-00-277-3504	1	WISE, MACHINE TABLE	3
5120-00-180-0681	2	WISE, MACHINIST'S: 4-in. jaw	2-3-7-9
5120-00-293-1439	2	WISE, MACHINIST'S: 4-in. jaw	7-9-15- 16

Table 3. Electrical Components to be Mounted

Part No. or NSN	Qty	Description	Figure no.
APPLETON 15233	32	BOX CONNECTOR: type I, class 4, style M (W-F-406)	41-43- 44-45- 46-47
4910-00-800-1405	2	CABLE ASSEMBLY, ELECTRICAL POWER: (MIL-C-45820)	41

3. Location of Equipment--Continued

Table 3. Electrical Components to be Mounted--Continued

Part No. or NSN	QTY	Description	Figure no.
11021163	2	CABLE ASSEMBLY, POWER consisting of one each of the following: 44-in. flex. cord (J-C-580) connector (W-C-596/92-1) box connector (W-F-406)	40-42- 43-44
11021164	2	CABLE ASSEMBLY, POWER consisting of one each of the following: 44-in. flex. cord (J-C-580) plug (W-C-596/91-1) box connector (W-F-406)	40-42- 43-45
11021165	2	CABLE ASSEMBLY, POWER consisting of one each of the following: 37.50-in. flex. cord (J-C-580) plug (W-C-596/91-1) box connector (W-F-406)	40-41- 43-46
11021166	2	CABLE ASSEMBLY, POWER consisting of one each of the following: 37.50-in. flex. cord (J-C-580) connector (W-C-596/92-1) box connector (W-F-406)	40-41- 43-47
GE-GLD0533	4	CONNECTOR, CABLE OUTLET: 2 pole, 3 wire, 30 amp, grounding, 125 V, 50/60 Hz (W-C-596/92-1)	44-47
GE-GLD0531	4	CONNECTOR, PLUG: straight, grounding, 2 pole, 3 wire, 30 amp, 125 V, 50/60 Hz (W-C-596/91-1)	45-46
6145-00-295-0855	84 ft	CORD, FLEXIBLE: type S06CF3/10SRNJG (J-C-580)	40-41- 43-44- 45-46- 47
APPLETON 2510	8	COVER, JUNCTION BOX, DUPLEX: type VIII, size F, style 59 (W-J-800)	41-42
5975-00-281-0090	8	JUNCTION BOX, DUPLEX: type II (W-J-800)	40-41- 42-43

3. Location of Equipment--Continued

Table 3. Electrical Components to be Mounted--Continued

Part No. or NSN	QTY	Description	Figure no.
APPLETON 40-3/4	8	JUNCTION BOX , LAMPHOLDER : type I (W-J-800)	40 thru 43
GE-5740-7	8	LAMPHOLDER, GENERAL ELECTRIC	41-42
5935-01-058-9269	8	CONNECTOR RECEPTACLE, GROUNDED: 2 pole, 3 wire (W-C-596/40)	41-42
SQUARE D D221NRB	2	SWITCH BOX (ENCLOSED): surface mtd, type NiDS, class 2, design 2SN BOX, 120/240 Vat, 30 amp (W-S-865)	41-43
MS20659-141	54	TERMINAL LUG	43

4. Installation

NOTE

Hand blind riveter (5120-00-679-6523) is used for installing blind rivet nuts in the floors and walls of units 1 thru 6. Hand blind riveter (5120-00-357-6065) is used for installing blind rivets (MS20601-Mp6W2) in storage cabinet wall in unit 3. Install blind rivet nuts in accordance with MIL-N-47187.

Unit 1. Follow steps (1) and (2) below for blind rivet nut and strap loop installation.

NOTE

Position floor- and table-top-mounted equipment as shown in figures 2 thru 5. Use equipment mounting holes as template for location of drilled mounting holes in accordance with figure 2.

(1) Mark and drill twelve 0.25-in. diameter holes in front and rear walls in accordance with figures 3, 4, and 5. Install twelve #10-32UNF blind rivet nuts (A10-180).

(2) Install six strap loops (MS51939-3) to installed blind rivet nuts using twelve #10-32UNF x 1-in. counter head machine screws (MS35191-276).

b. Follow steps (1) thru (13) below for equipment installation in unit 1.

(1) Mark and drill sixteen 0.34-in. diameter holes through horizontal leg of factory-furnished, wall-mounted angle irons in accordance with figure 2.

(2) Position two 60-in. tables (4910-00-543-7772) and two 72-in. tables w/drawers (4910-00-543-7771) under factory-furnished angle iron in accordance with figures 2, 3, and 4. Using drilled angle iron as a template, mark and drill sixteen 0.22-in. diam-

4. Installation--Continued

eter pilot holes into the tabletops. Mark and drill twelve 0.22-in. diameter pilot holes through table legs into van floor on aisle side only (three per table). Enlarge holes in table legs to 0.34-in. diameter. Secure tables to angle irons and floor of van using twenty-eight 5/16- x 1-1/4-in. hex head lag bolts (MS16992-521) and twenty-eight 5/16-in. lockwashers (MS35338-45).

(3) Position utility grinder (3415-00-517-7754) on 72-in. table w/drawers in accordance with figures 2 and 4. Using utility grinder base as a template, mark and drill three 0.34-in. diameter holes through tabletop. Secure utility grinder to tabletop using three 5/16- x 2-3/4-in. hex head capscrews (MS90725-43), three 5/16-in. flat washers (MS27183-11), three 5/16-in. lockwashers (MS35338-45), and three 5/16-in. hex nuts (MS51967-5).

(4) Position valve face grinding machine (4910-00-540-4679) on top of 72-in. table w/drawers in accordance with figures 2 and 4. Using valve face grinding machine base as a template, mark and drill two 0.56-in. diameter holes through tabletop. Secure valve face grinding machine to tabletop using two 1/2- x 3-1/4-in. hex head capscrews (MS90725-120), two 1/2-in. flat washers (MS27183-17), two 1/2-in. lockwashers (MS35338-48), and two 1/2-in. hex nuts (MS51967-14).

(5) Position drill stand (5130-00-263-8657) on top of 60-in. table in accordance with figures 2 and 3. Using drill stand base as a template, mark and drill three 0.38-in. diameter holes through tabletop. Secure drill stand to tabletop using three 5/16- x 2-3/4-in. hex head capscrews (MS90725-43), three 5/16-in. flat washers (MS27183-11), three 5/16-in. lockwashers (MS35338-45), and three 5/16-in. hex nuts (MS51967-5). Secure machine table vise (3460-00-277-3504) to drill stand

in accordance with figure 3 using T-bolts and nuts provided with machine table vise.

(6) Position and secure portable electric drill (5130-00-473-6228) to drill stand in accordance with figure 3.

(7) Position 3-in. machinist's vise (5120-00-180-0681) on top of 72-in. table in accordance with figures 2 and 3. Using 3-in. machinist's vise base as template, mark and drill four 0.56-in. diameter holes through tabletop. Secure 3-in. machinist's vise to tabletop using four 1/2- x 3-1/4-in. hex head capscrews (MS90725-120), four 1/2-in. flat washers (MS27183-17), four 1/2-in. lockwashers (MS35338-48), and four 1/2-in. hex nuts (MS51967-14).

(8) Position hose assembler (4940-01-091-5099), a component of hose assembly outfit (4940-01-080-4213), on top of 60-in. table in accordance with figures 2 and 4. Using hose assembler base as template, mark and drill four 0.41-in. diameter holes through tabletop. Secure hose assembler to tabletop using four 3/8- x 2-1/4-in. hex head capscrews (MS90725-67), four 3/8-in. flat washers (MS27183-13), four 3/8-in. lockwashers (MS35338-46), and four 3/8-in. hex nuts (MS51967-8).

(9) Position three mechanic's creepers (4910-00-251-6981) upright against front wall in accordance with figures 2 and 5. Secure to front wall using two 92-in. retaining straps (7550588-7).

(10) Position four trestles (4310-00-251-8013) in rear van corners in accordance with figures 2, 3, and 4. Secure using two 36-in. retaining straps (7550588-4) passed around one table leg.

(11) Stow two radiator filling cans (7240-00-499-8028), three portable electric drills (5130-00-473-6228), 30-

4. Installation--Continued

ton hand hydraulic jack (5120-00-188-1790), bead breaker (4910-01-015-7667), electric etcher (5130-00-203-7943), two 8-qt liquid measures (7240-00-255-5996), industrial faceshield (4240-00-202-9473), two 1-liter liquid measures (7240-00-889-3765), filler and bleeder (4910-00-273-3658), and two 2-qt liquid measures (7240-00-255-8113) on shelves of 60-in. table in accordance with figure 3.

(12) Stow six 24-ft extension lights (6230-00-729-9259) on top shelf of 72-in. table w/drawers in accordance with figure 4.

(13) Stow hose assembly outfit (4940-01-080-4213), 35-degree angle valve seat grinding kit (4910-00-060-9983), one 7-ft cable assembly (4910-00-800-1405), three 50-ft cable assemblies (6150-00-682-3460), valve seat grinding kit (4910-00-473-6437), two collet set machines (3460-01-109-7664), five 25-ft power cable assemblies (4910-00-725-9558), and cable kit (2590-00-148-7961) on shelves of 60-in. table in accordance with figure 4.

Follow steps (1) thru (3) below for blind rivet nut and strap loop installation.

NOTE

Position floor-mounted storage cabinets and equipment as shown in figures 7, 8, and 9. Use equipment mounting holes as templates for location of drilled mounting holes. Positions may be varied to drill into structural members in floor.

(1) Mark and drill fourteen 0.25-in. diameter holes in front and left side walls in accordance with figures 11 and 12. Install fourteen #10-32UNF blind rivet nuts (A10-180). Secure seven strap loops (MS51939-3) in accordance

with figures 7 and 9 to blind rivet nuts using fourteen #10-32UNF x 1-in. counter head machine screws (MS35191-276).

(2) Mark and drill 1 twenty-six 0.22-in. diameter holes through floor in accordance with figure 10. Secure thirteen strap loops (MS51939-3) in accordance with figure 7 to floor using twenty-six #10-32UNF x 1-in. counter head machine screws (MS35191-276), twenty-six #10 lockwashers (MS35338-43), and twenty-six #10-32UNF hex nuts (MS35650-302).

(3) Mark and drill four 0.22-in. diameter holes in front vail wood slat in accordance with figure 12. Secure two strap loops (MS51939-3) in accordance with figure 7 to slat using four #10 x 1-1/4-in. countersunk head machine screws (MS35190-276), four 7/32-in. flat washers (MS27183-42), four #10 lockwashers (MS35338-43), and four #10-32UNF hex nuts (MS35650-302).

d. Follow steps (1) thru (15) below for equipment installation in unit 2.

(1) Position four mechanic's creepers (4910-00-251-6981) lengthwise against the front wall in accordance with figures 7 and 9. Secure to front wall using two 66-in. retaining straps (7550588-9) .

(2) Position arbor press (3444-00-449-7295) in front end of truck in accordance with figures 7 and 8. Using arbor press base as template, mark and drill four 0.50-in. diameter holes through truck floor in accordance with figure 10. Secure arbor press to floor using four 7/16- x 1-3/8-in. hex head capscrews (MS90725-88), four 7/16-in. flat washers (MS27183-15), four 7/16-in. lockwashers (MS35338-47), and four 7/16-in. hex plain nuts (MS51967-11).

(3) Position dolly-type jack (4910-00-289-7233) in front right corner in accordance with figures 7 and 8. Position three ground rods (5975-00-777-6781) between right side wall

4. Installation--Continued

and dolly-type jack in accordance with figure 7. Secure dolly-type jack and ground rods to floor using two 66-in. retaining straps (7550588-9).

(4) Position four trestles (4910-00-251-8013) next to arbor press in accordance with figures 7 and 8. Secure to floor of truck using 110-in. retaining strap (7550588-10).

(5) Position two drain pans (4910-00-387-9592) on the right side wood slats in accordance with figures 7 and 8. Secure drain pans to wood slats using two 66-in. retaining straps (7550588-9).

(6) Position brake drum lathe (4910-01-028-9849) in accordance with figures 7 and 8. Using brake drum lathe base as template, mark and drill four 0.50-in. diameter holes through truck floor in accordance with figure 10. Secure brake drum lathe to floor using four 7/16- x 1-1/4-in. hex head capscrews (MS90725-87), four 7/16-in. flat washers (MS27183-15), four 7/16-in. lockwashers (MS35338-47), and four 7/16-in. hex plain nuts (MS51967-11).

(7) Mark and drill two 0.44-in. diameter holes in the front corners of bottom plates of three storage cabinets (7125-00-330-0130), allowing for minimum required clearance for 3/8-in. hex head capscrews. Position the three storage cabinets in left rear corner of truck in accordance with figures 7 and 9. Using the storage cabinet bases as templates, mark and drill six 0.44-in. diameter holes through truck floor in accordance with figure 10. Secure storage cabinets to floor using six 3/8- x 1-1/8-in. hex head capscrews (MS90725-61), six 3/8-in. flat washers (MS27183-13), six 3/8-in. lockwashers (MS35338-46), and six 3/8-in. hex nuts (MS51967-8).

(8) Mark and drill four 0.25-in. diameter holes in side of storage cabinet in accordance with figure 14. Install four #10-32UNF blind rivet nuts (A10-180). Position and secure two strap loops (MS51939-3) in accordance with figure 7 to blind rivet nuts using four #10-32UNF x 1-in counter head machine screws (MS35191-276).

(9) Position two 12-ton hand hydraulic jacks (5120-00-224-7330) against front wall in accordance with figures 7 and 8. Secure to front wall using 48-in. retaining strap (7550588-3).

(10) Position two engine transport stands (4910-00-338-6673) against front left wall in accordance with figures 7 and 9. Secure to wall, floor, and storage cabinet side using two 36-in. retaining straps (7550588-4) and four 48-in. retaining straps (7550588-3) in accordance with figures 7 and 9. Two of the 48-in. retaining straps are wrapped around truck slats.

(11) Position 3-in. machinist's vise (5120-00-180-0681) and 4-in. machinist's vise (5120-00-293-1439) on edges of storage cabinets in accordance with figures 7 and 9. Using vise bases as templates, mark and drill eight 0.56-in. diameter holes through tops of storage cabinets. Secure 3-in. and 4-in. machinist's vises to cabinet tops using eight 1/2- x 3-1/4-in. hex head capscrews (MS90725-120), eight 17/32-in. flat washers (MS27183-18), eight 1/2-in. lockwashers (MS35338-48), and eight 1/2-in. hex nuts (MS51967-14).

(12) Position generator test set (4910-00-092-9136) on top of storage cabinets in accordance with figures 7 and 9. Secure to storage cabinet drawer handle and truck slat using 110-11, retaining strap (7550588-10).

4. Installation--Continued

(13) Mark and drill four 0.09-in. diameter pilot holes on rear storage cabinet top in accordance with figure 13. Position and secure two strap loops (MS51939-3) using four #10 x 1-in. flat head wood screws (MS35492-78).

(14) Position ten wash pans on rear storage cabinet top in accordance with figures 7 and 9. Secure to cabinet top using 110-in. retaining strap (7550588-10).

(15) Position transmission and differential lift (4910-00-585-3622) on rear floor in accordance with figures 7 and 8. Secure to floor using two 92-in. retaining straps (7550588-7).

Follow steps (1) thru (3) below for blind rivet nut and strap loop installation.

NOTE

Position floor- and cabinet top-mounted equipment as shown in figures 15 and 17. Use equipment mounting holes as a template for location of drilled mounting holes in accordance with figure 18.

(1) Mark and drill fourteen 0.25-in. diameter holes in front and left wall in accordance with figures 19 and 20. Install fourteen #10-32UNF blind rivet nuts (A10-180). Secure seven strap loops (MS51939-3) to blind rivet nuts using fourteen #10-32UNF x 1-in. counter head machine screws (MS35191-276).

(2) Mark and drill four 0.22-in. diameter holes through floor in accordance with figure 18. Secure two strap loops (MS51939-3) to floor using four #10-32UNF x 1-in. counter head machine screws (MS35191-276), four #10 lockwashers (MS35338-43), and four #10-32UNF hex nuts (MS35650-302).

(3) Mark and drill twenty 0.22-in. diameter holes in the front and left wall slats in accordance with figures 19 and 20. Secure ten strap loops (MS51939-3) using twenty #10 x 1-1/4-in. counter head machine screws (MS35190-276), twenty 7/32-in. flat washers (MS27183-42), twenty #10 lockwashers (MS35338-43), and twenty #10-32UNF hex nuts (MS35650-302).

f. Follow steps (1) thru (15) below for equipment installation in unit 3.

(1) Position two 72-in. tables (4910-00-357-5342) against the right side wall in accordance with figure 15. Mark and drill sixteen 0.34-in. diameter holes through table leg pads and truck floor in accordance with figure 18. Secure 72-in. tables to floor using sixteen 5/16- x 1-1/4-in. hex head capscrews (MS90725-36), thirty-two 11/32-in. flat washers (MS27183-12), sixteen 5/16-in. lockwashers (MS35338-45), and sixteen 5/16-in. hex nuts (MS51967-5).

(2) Mark and drill two 0.44-in. diameter holes in the front corners of each bottom plate of three storage cabinets (7125-00-330-0130) allowing for minimum required clearance for 3/8-in. hex head capscrews. Position the three storage cabinets in left rear corner of truck in accordance with figures 15 and 17. Using the storage cabinet bases as templates, mark and drill six 0.44-in. diameter holes through truck floor in accordance with figure 18. Secure storage cabinets to floor using six 3/8- x 1-1/8-in. hex head capscrews (MS90725-61), six 3/8-in. flat washers (MS27183-13), six 3/8-in. lockwashers (MS35338-46), and six 3/0-in. hex nuts (MS51967-8).

(3) Mark and drill two 0.19-in. diameter holes through right side wall of storage cabinet in accordance with figure 21. Secure one strap loop

4. Installation--Continued

(MS51939-3) to storage cabinet side using two 3/16-in. blind rivets (MS20601-MP6W2).

(4) Position three oxygen cylinders (8120-00-151-9758) on front wall in accordance with figure 15. Secure to wall using six 36-in. retaining straps (7550588-4) in accordance with figure 16.

(5) Position dolly-type jack (4910-00-289-7233) on front floor next to the oxygen cylinders and under the 72-in. table in accordance with figure 15. Secure dolly-type jack to floor in accordance with figure 16 using 36-in. retaining strap (7550588-4).

(6) Position degreaser (4940-00-449-6689) in front left corner of truck in accordance with figures 15 and 17. Secure to wall slats using 110-in. retaining strap (7550588-10).

(7) Position four trestles (4910-00-251-8013) between right side of storage cabinet and degreaser in accordance with figures 15 and 17. Secure trestles to storage cabinet and truck wall using 36-in. retaining strap (7550588-4).

(8) Position five mechanic's creepers (4910-00-251-6981) under 72-in. table in accordance with figures 15 and 16. Secure to table leg using 30-in. retaining strap (7550588-8).

(9) Position two 8-ton hand hydraulic jacks (5120-00-595-8396) under 72-in. table in accordance with figures 15 and 16. Secure to table leg using 36-in. retaining strap (7550588-4).

(10) Position six 20-ft extension lights (6230-00-268-9436) and two 7-ft power cable assemblies (4910-00-800-1405) on truck slat in accordance with figures 15 and 16. Secure using eight 24-in. retaining straps (7550588-5).

(11) Position hoisting unit (4910-00-448-0254) on truck floor between 72-in. tables and storage cabinets in accordance with figures 15 and 16. Secure hoisting unit to table cross brace using 36-in. retaining strap (7550588-4).

(12) Position 4-in. machinist's vise (5120-00-293-1439) on top of rear 72-in. table in accordance with figures 15 and 16. Using 4-in. machinist's vise base as a template, mark and drill four 0.56-in. diameter holes through tabletop. Secure 4-in. machinist's vise to tabletop using four 1/2- x 3-1/4-in. hex head capscrews (MS90725-120), four 1/2-in. flat washers (MS27183-17), four 1/2-in. lockwashers (MS35338-48), and four 1/2-in. hex nuts (MS51967-14).

(13) Position disk sander (5130-00-857-8526) on top of 72-in. table in accordance with figures 15 and 16. Secure to truck slat using 24-in. retaining strap (7550588-5).

(14) Position transmission and differential lift (4910-00-585-3622) on rear floor of truck in accordance with figures 15 and 16. Secure transmission and differential lift to 72-in. table's cross brace using 36-in. retaining strap (7550588-4).

(15) Position hand truck (3920-01-113-0117) in rear left corner in accordance with figures 15 and 17. Secure acetylene cylinder (8120-00-268-3360) and oxygen cylinder (8120-00-151-9758) to hand truck in accordance with figure 15 using 92-in. retaining strap (7550588-7). Secure hand truck with acetylene and oxygen cylinders to truck slats using 92-in. retaining strap (7550588-7).

Follow steps (1) and (2) below for blind rivet nut and strap loop installation.

4. Installation--Continued

NOTE

Position floor-mounted equipment as shown in figures 23, 24, and 25. Use equipment mounting holes as template for location of drilled mounting holes in accordance with figure 26.

(1) Mark and drill eighteen 0.25-in. diameter holes in right and left side walls of trailer in accordance with figures 27 and 28. Install eighteen #10-32UNF blind rivet nuts (A10-180). Secure nine strap loops (MS51939-3) using eighteen #10-32UNF x 1-in. counter head machine screws (MS35191-276).

(2) Mark and drill two 0.22-in. diameter holes through trailer floor in accordance with figure 26. Secure strap loop (MS51939-3) to floor using two #10-32UNF x 1-in. counter head machine screws (MS35191-276), two #10 lockwashers (MS35338-43), and two #10-32UNF hex nuts (MS35650-302).

h. Follow steps (1) thru (8) below for equipment installation in unit 4.

(1) Position compressor (4310-00-542-4566) in front of trailer in accordance with figures 23 and 24. Using holes in compressor legs as template, mark and drill four 0.56-in. diameter holes through floor in accordance with figure 26. Secure compressor to floor using four 1/2- x 2-in. hex head capscrews (MS90725-115), four 1/2-in. lockwashers (MS35338-48), and four 1/2-in. hex nuts (MS51967-14).

(2) Position motor vehicle engine and transmission sling (4910-00-944-4915) against trailer wall in front left corner in accordance with figures 23 and 25. Secure to trailer slat using 24-in. retaining strap (7550588-5).

(3) Position separator (4940-00-242-4101) on slat in front right wall in accordance with figures 23 and 24. Using separator mounting bracket as template, mark and drill two 0.12-in. diameter pilot holes in slat in accordance with figure 27. Secure separator to slat using two #14 x 7/8-in. round head wood screws (MS35495-125) and two 1/4-in. lockwashers (MS35338-44).

(4) Position 4-qt liquid measure (7240-00-233-6015) in front right corner of trailer in accordance with figures 23 and 24. Secure to right wall using 24-in. retaining strap (7550588-5).

(5) Position lubricating unit (4930-00-720-4849) against left front wall in accordance with figures 23 and 25. Secure to wall using 48-in. retaining strap (7550588-3).

(6) Position two oil bucket pumps (4930-00-244-4860) against right side wall in accordance with figures 23 and 24. Secure to wall using two 48-in. retaining straps (7550588-3).

(7) Position diesel engine generator set (6115-00-465-1044) in rear of trailer in accordance with figure 23. Using diesel engine generator set base as template, mark and drill four 0.62-in. diameter holes through floor in accordance with figure 26. Secure diesel engine generator set to floor using four 1/2- x 1-1/2-in. hex head capscrews (MS90725-113), four 1/2-in. lockwashers (MS35338-48), and four 1/2-in. hex nuts (MS51967-14).

(8) Position tool box (5140-00-315-2758) on rear left corner floor in accordance with figure 23. Secure to trailer wall and floor using 48-in. retaining strap (7550588-3).

i. Unit 5. Follow the procedure below for blind rivet nut and strap loop installation.

4. Installation--Continued

NOTE

Position floor-mounted equipment as shown in figures 29, 30, and 31. Use equipment mounting holes as template for location of drilled mounting holes in accordance with figure 32.

Mark and drill twelve 0.25-in. diameter holes in the right and left side walls in accordance with figures 33 and 34. Install twelve #10-32UNF blind rivet nuts (A10-180). Secure six strap loops (MS51939-3) to walls using twelve #10-32UNF x 1-in. counter head machine screws (MS35191-276).

Follow steps (1) thru (5) below for equipment installation in unit 5.

(1) Position separator (4940-00-242-4101) on front right corner slat in accordance with figures 29 and 30. Using separator mounting bracket as template, mark and drill two 0.12-in. diameter pilot holes in trailer slat in accordance with figure 34. Secure separator to slat using two #14 x 7/8-in. round head wood screws (MS35495-125) and two 1/4-in. lockwashers (MS35338-44).

(2) Position compressor (4310-00-542-4566) in front of trailer in accordance with figures 29 and 30. Using holes in compressor legs as template, mark and drill four 0.56-in. diameter holes through floor in accordance with figure 32. Secure compressor to floor using four 1/2- x 2-in. hex head capscrews (MS90725-115), four 1/2-in. lockwashers (MS35338-48), and four 1/2-in. hex nuts (MS51967-14).

(3) Position lubricating unit (4930-00-720-4849) against the front left wall in accordance with figures 29 and 31. Secure to wall using 48-in. retaining strap (7550588-3).

(4) Position two grease bucket pumps (4930-00-244-4859) against right side wall in accordance with figures 29 and 30. Secure to wall using two 48-in. retaining straps (7550588-3).

(5) Position steam cleaner (4940-00-186-0027) in center of trailer in accordance with figures 29, 30, and 31. Using the steam cleaner skid as template, mark and drill eight 0.38-in. diameter holes through trailer floor in accordance with figure 32. Secure steam cleaner to floor using four 5/16-in. U-bolts (8875T37), eight 5/16-in. lockwashers (MS35338-45), and eight 5/16-in. hex plain nuts (MS51972-2).

Follow steps (1) thru (3) below for blind rivet nut and strap loop installation.

NOTE

Position floor-mounted equipment as shown in figures 35, 37, and 38. Use equipment mounting holes as template for location of drilled mounting holes in accordance with figure 36.

(1) Mark and drill twelve 0.25-in. diameter holes in right and left side walls in accordance with figures 37 and 38. Install twelve #10-32UNF blind rivet nuts (A10-180). Secure six strap loops (MS51939-3) to walls using twelve #10-32UNF x 1-in. counter head machine screws (MS35191-276).

(2) Mark and drill four 0.22-in. diameter holes through floor in accordance with figure 36. Secure two strap loops (MS51939-3) to floor using four #10-32UNF x 1-in. counter head machine screws (MS35191-276), four #10 lockwashers (MS35338-43), and four #10-32UNF hex nuts (MS35650-302).

(3) Mark and drill eight 0.22-in. diameter holes through right and left side wall slats in accordance with

4. Installation--Continued

figures 37 and 38. Secure four strap loops (MS51939-3) to slats using eight #10 x 1-1/4-in. countersunk head machine screws (MS35190-276), eight 7/32-in. flat washers (MS27183-42), eight #10 lockwashers (MS35338-43), and eight #10-32UNF hex nuts (MS35650-302).

1. Follow steps (1) thru (11) below for equipment installation in unit 6.

(1) Position gas engine generator set (6115-00-017-8236) at front center of trailer in accordance with figure 35. Using the franc base of gas engine generator set as a template, mark and drill four 0.44-in. diameter holes through floor in accordance with figure 36. Secure gas engine generator set to floor using four 3/8- x 2-1/4-in. hex head capscrews (MS90725-67), eight 3/8-in. lockwashers (MS35338-46), and four 3/8-in. hex nuts (MS51967-8).

(2) Position tire spreader (4910-00-725-0326) in center of trailer in accordance with figures 35 and 37. Using tire spreader base as a template, mark and drill four 0.44-in. diameter holes through floor in accordance with figure 36. Secure tire spreader to floor using four 3/8- x 1-3/8-in. hex head capscrews (MS90725-63), four 3/8-in. lockwashers (MS35338-46), and four 3/8-in. hex nuts (MS51967-8).

(3) Position three mechanic's creepers (4910-00-251-6981) against rear right wall in accordance with figures 35 and 37. Secure mechanic's creepers to wall using two 92-in. retaining straps (7550588-7) .

(4) Position welding rod rack (3439-00-564-5793) and tool box (5140-00-315-2758) in rear left corner in accordance with figures 35 and 38. Secure welding rod rack using 66-in. retaining strap (7550588-9), and tool box using 110-in. retaining strap (7550588-10), to left side wall.

(5) Position two tool boxes (5140-00-315-2758), one on top of each wheel well, in accordance with figures 35, 37, and 38. Secure to wall slat and floor using two 66-in. retaining straps (7550588-9) .

NOTE

The following installed hoses are components of hose assembly outfit (4940-01-080-4213). The hose assembly outfit is installed and stowed in unit 1.

(6) Position both 20 foot long 2.00-in. od hose (4720-00-432-7204) and 2.31-in. od hose (4720-01-075-2106) against front wall in accordance with figures 35 and 39. Secure to slat using two 24-in. retaining straps (7550588-5).

(7) Position both 100 foot long 1.25-in. od hose (4720-00-080-3085) and 1.00-in. od hose (4720-01-018-6550) against right side wall slats in accordance with figures 35 and 37. Secure to slats using two 48-in. retaining straps (7550588-3).

(8) Position 20 foot long, 1.75-in. od hose (4720-00-893-5017) and 60 foot long, 1.56-in. od hose (4720-00-289-2618) against front left wall slats in accordance with figures 35 and 38. Secure to slats using 48-in. retaining strap (7550588-3).

(9) Position 100 foot long, 0.84-in. od hose (4720-00-289-2615) against the center left wall slats in accordance with figures 35 and 38. Secure to slats using 48-in. retaining strap (7550588-3).

(10) Position 60 foot long, 0.66-in. od hose (4720-01-017-5127) against left rear wall slats in accordance with figures 35 and 38. Secure to slats using 30-in. retaining strap (7550588-8).

4. Installation--Continued

(11) Position 10 foot long, 2.75-in. od hose (4720-00-926-1083) on floor of trailer in accordance with figure 35. Secure to gas engine generator set frame using 24-in. retaining strap (7550588-5).

m. Units 2 and 3. Follow steps (1) thru (14) below for electrical component installation.

NOTE

This procedure is written for one unit. Refer to table 3 for total number of electrical components required for units 2 and 3.

(1) To provide sufficient headroom for personnel to work in the M35A2 cargo trucks, raise the bows 18 inches to a total height of 78 inches in accordance with figures 41 and 42, and drill ten 0.44-in. diameter holes through bow sockets and bows.

(2) Secure bows in place with ten 7/16- x 1-3/8-in. hex head capscrews (MS90725-88), ten 7/16-in. lockwashers (MS35338-47), and ten 7/16-in. hex plain nuts (MS51967-11).

(3) Position switch box (Square D D221NRB) on the two top slats in accordance with figure 41. Using holes of switch box as a template, mark and drill four 0.12-in. diameter pilot holes. Secure switch box to truck slat with four 1/4- x 1-in. tapping screws (MS51861-69).

(4) Install electrical power cable assembly (4910-00-800-1405) through box connector in bottom of switch box and connect to circuit breaker inside switch box in accordance with figure 41.

(5) Position four lampholder junction boxes (Appleton 40-3/4) on inner side of second and fourth bows as shown in figure 40. Mark and drill eight 0.12-in. diameter pilot holes and

secure lampholder junction boxes to bows with eight #10 x 1-in. tapping screws (MS51861-49).

(6) Position four duplex junction boxes (5975-00-281-0090) on bows as shown in figures 41 and 42. Mark and drill eight 0.12-in. diameter pilot holes and secure duplex junction boxes to bows with eight #10 x 1-in. tapping screws (MS51861-49).

(7) Remove two knockout slugs from each lampholder junction box and each duplex junction box in line with bows. Install twelve box connectors (Appleton 15233) in the junction boxes and install jam nuts on box connectors in accordance with figure 43.

(8) Fabricate four power cable assemblies (11021163, 11021164, 11021165, and 11021166) using approximately 14 feet of flexible cord (6145-00-295-0855). Install four box connectors (Appleton 15233). Refer to figures 44 thru 47 for individual power cable assembly construction, and install in accordance with figures 40 thru 43.

(9) Install 28 feet of flexible cord (6145-00-295-0855) through duplex junction boxes and lampholder junction boxes on second and fourth bows. Refer to figures 41 and 43. Strip a 3-in. length of outside insulation from flexible cord on inside of each junction box. Strip 1 inch of insulation from each individual wire and twist wire to fit terminal lugs (MS20659-141). Install and crimp terminal lugs in place in accordance with figure 43.

(10) Connect three wires to lampholder (GE-5740-7) and secure to lampholder junction box (Appleton 40-3/4) with screws provided with lampholder junction box. Repeat this step for remaining three lampholder junction boxes. Refer to figures 41 and 42.

4. Installation--Continued

(11) Install four grounded connector receptacles (5935-01-058-9269) after stripping 3 inches of outside insulation from flexible cord. Refer to figures 41 thru 43. Strip 1 inch of insulation from each individual wire and twist wires to fit terminal lugs (MS20659-141). Install terminal lugs and crimp. Connect wires to grounded duplex receptacles, and secure grounded duplex receptacles to duplex junction boxes with screws provided with grounded duplex receptacles in accordance with figures 41 and 42.

(12) Install four duplex junction box covers (Appleton 2510) to duplex junction boxes (5975-00-281-0090) and secure with screws provided in duplex junction box covers. Refer to figures 41 and 42.

(13) Tighten all box connectors (Appleton 15233) to secure flexible cords in junction boxes and switch box. Refer to figures 40 thru 47.

(14) Secure power cable assemblies to bows and truck rack with twenty-eight tiedown straps (MS3367-3-0) in accordance with figures 40 thru 42.

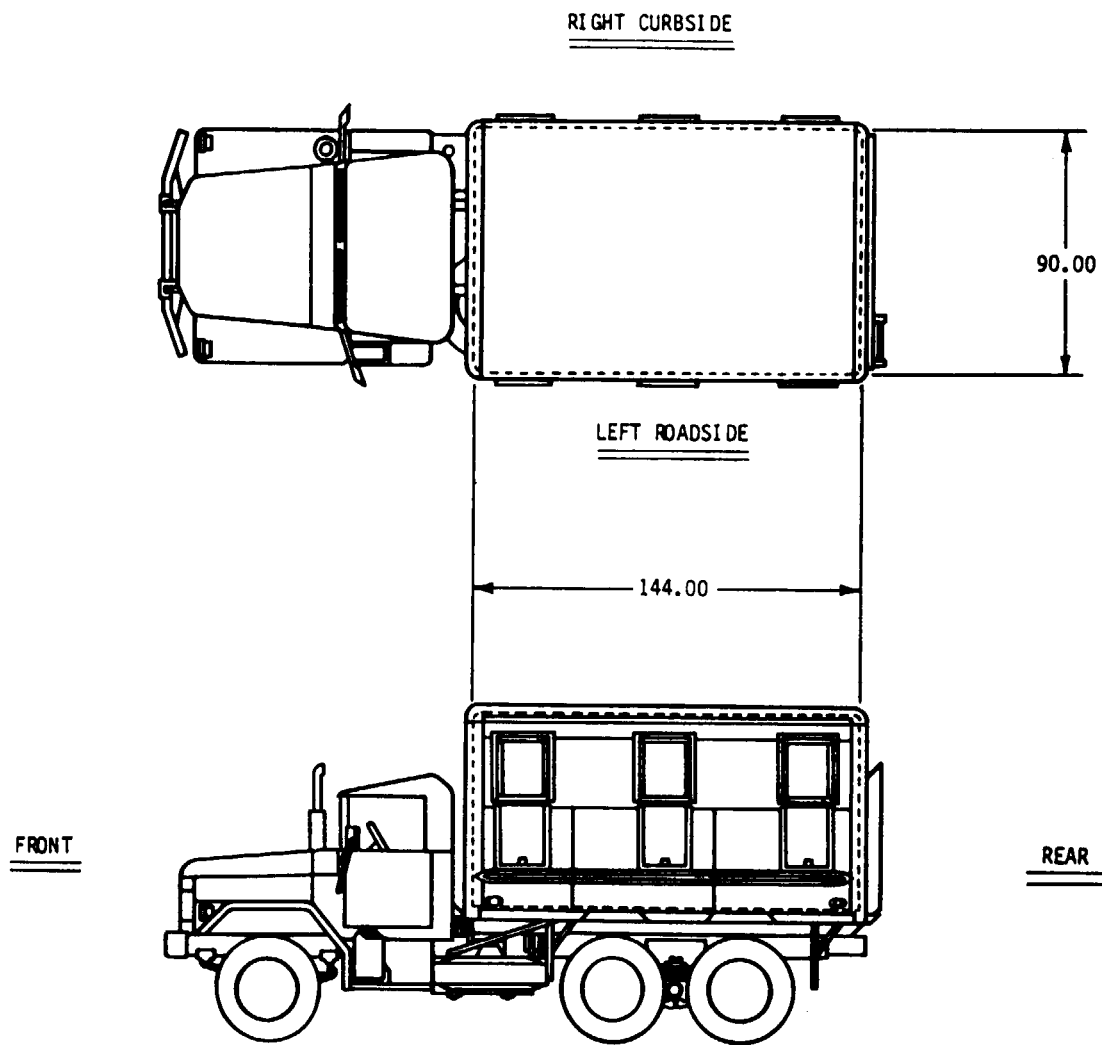

Figure 1. M109A3 Shop Van Truck, Unit 1.

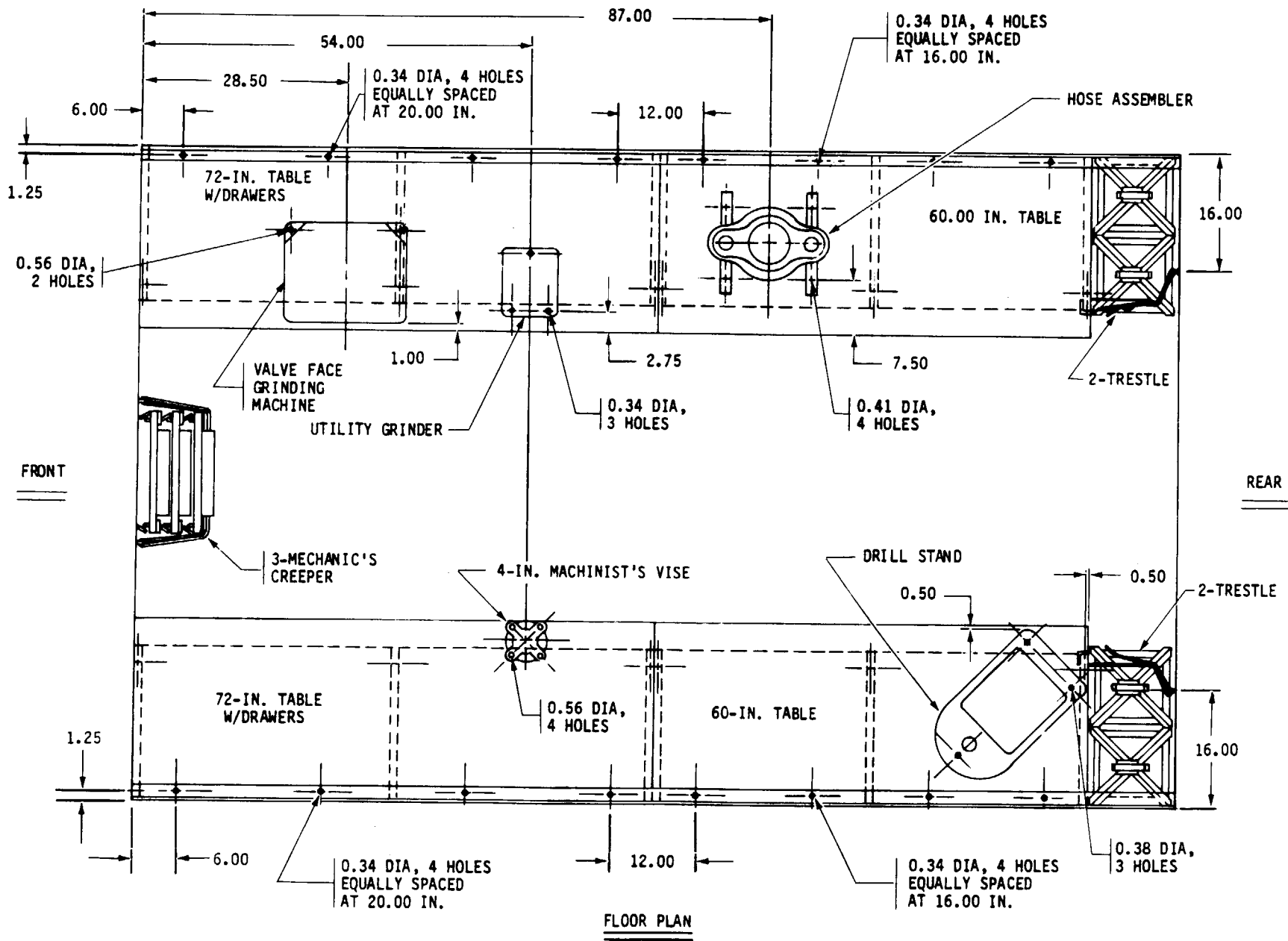

Figure 2. Components to be Mounted, Unit 1, M109A3, Floor Plan.

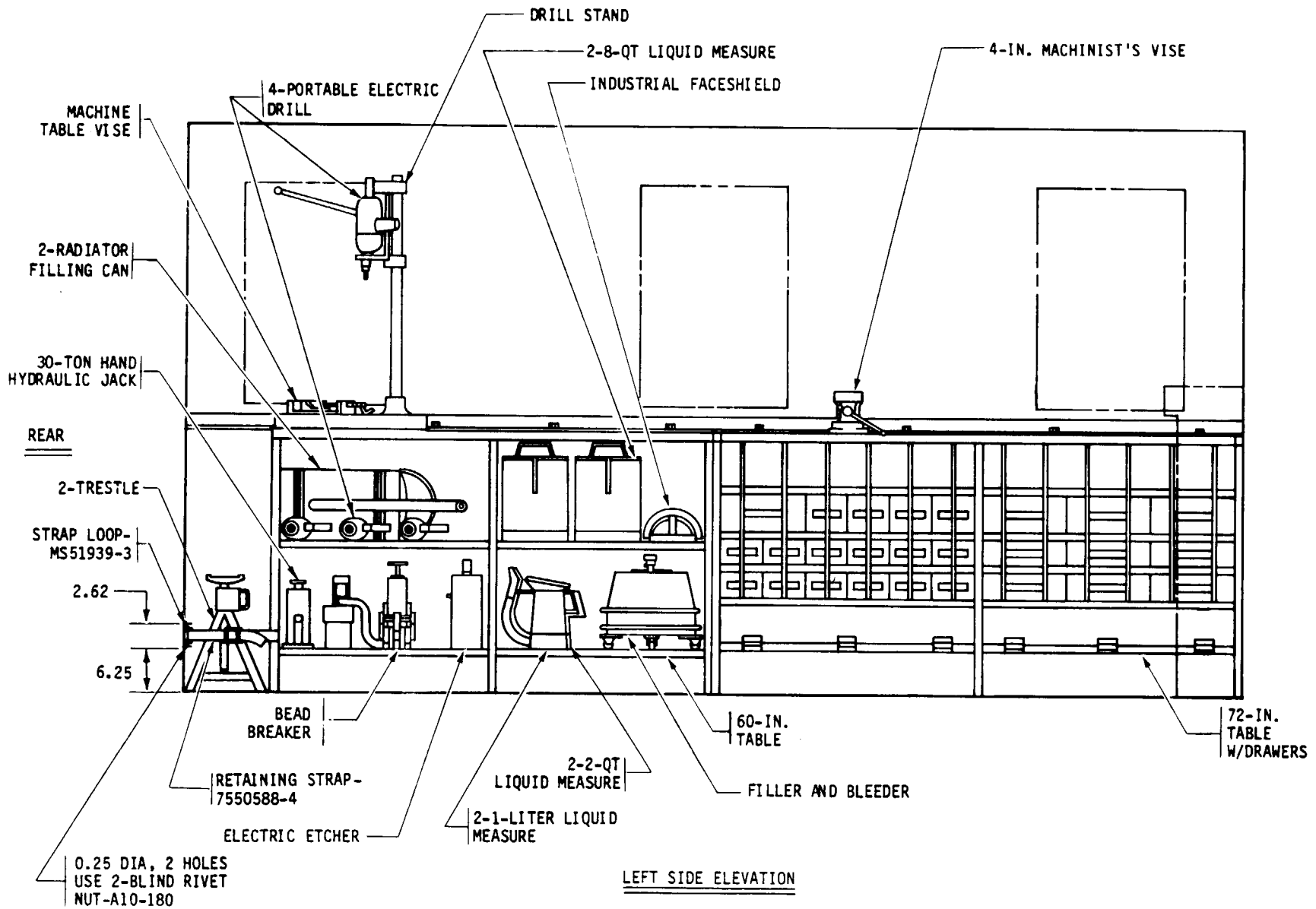

Figure 3. Components to be Mounted, Unit 1, M109A3, Left Side Elevation.

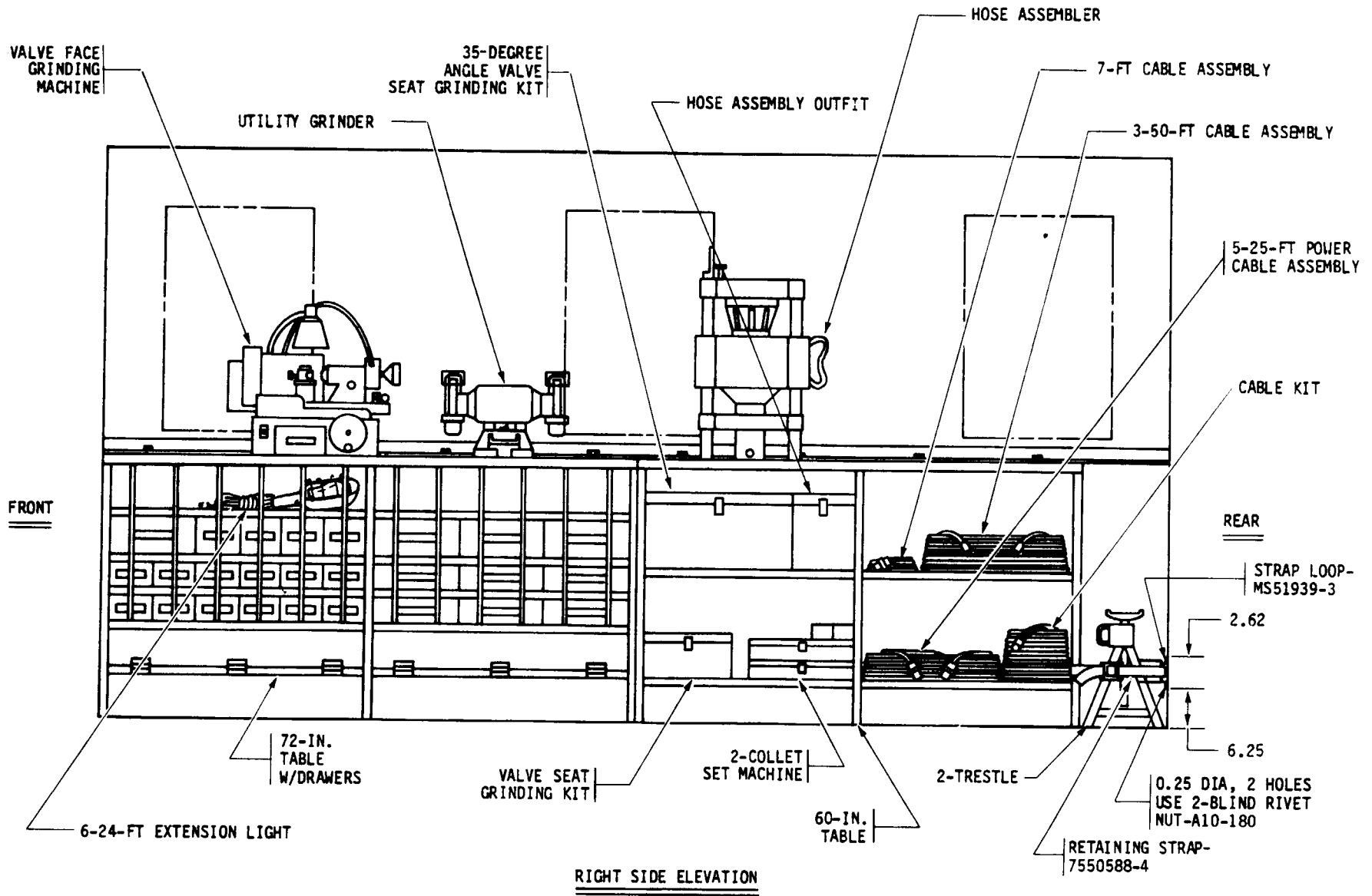
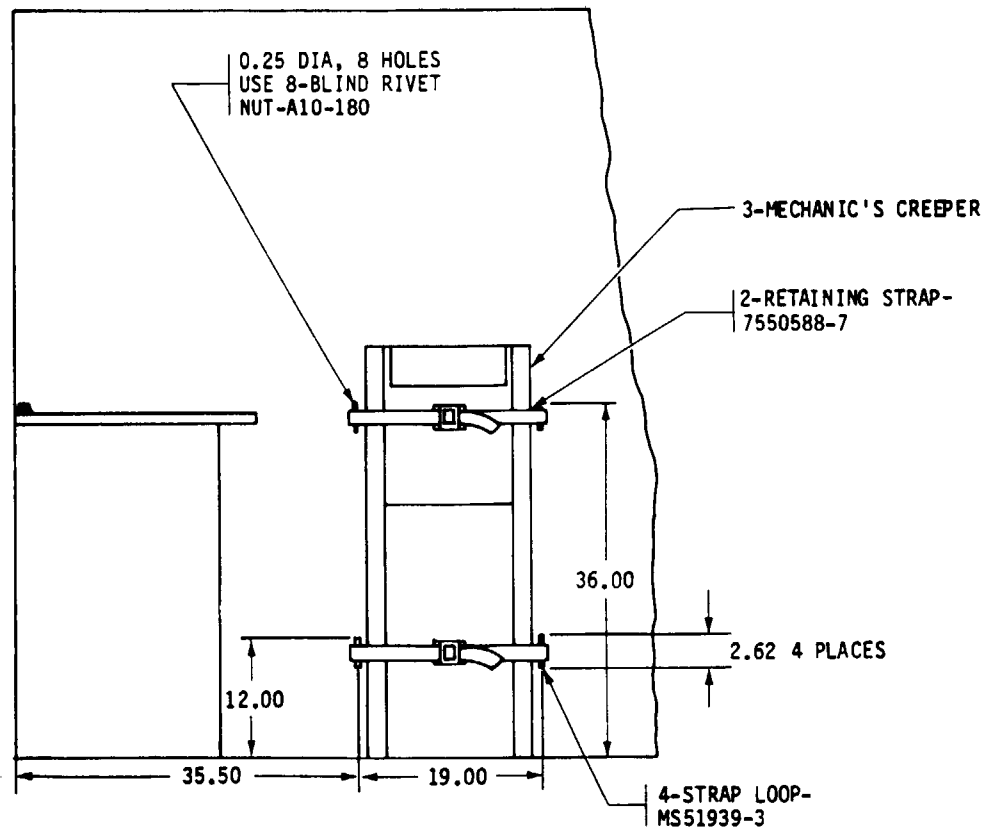

Figure 4. Components to be Mounted, Unit 1, M109A3, Right Side Elevation.

LEFT SIDE



FRONT WALL ELEVATION

Figure 5. Location of Strap Loops, Front Wall, Unit 1, M109A3.

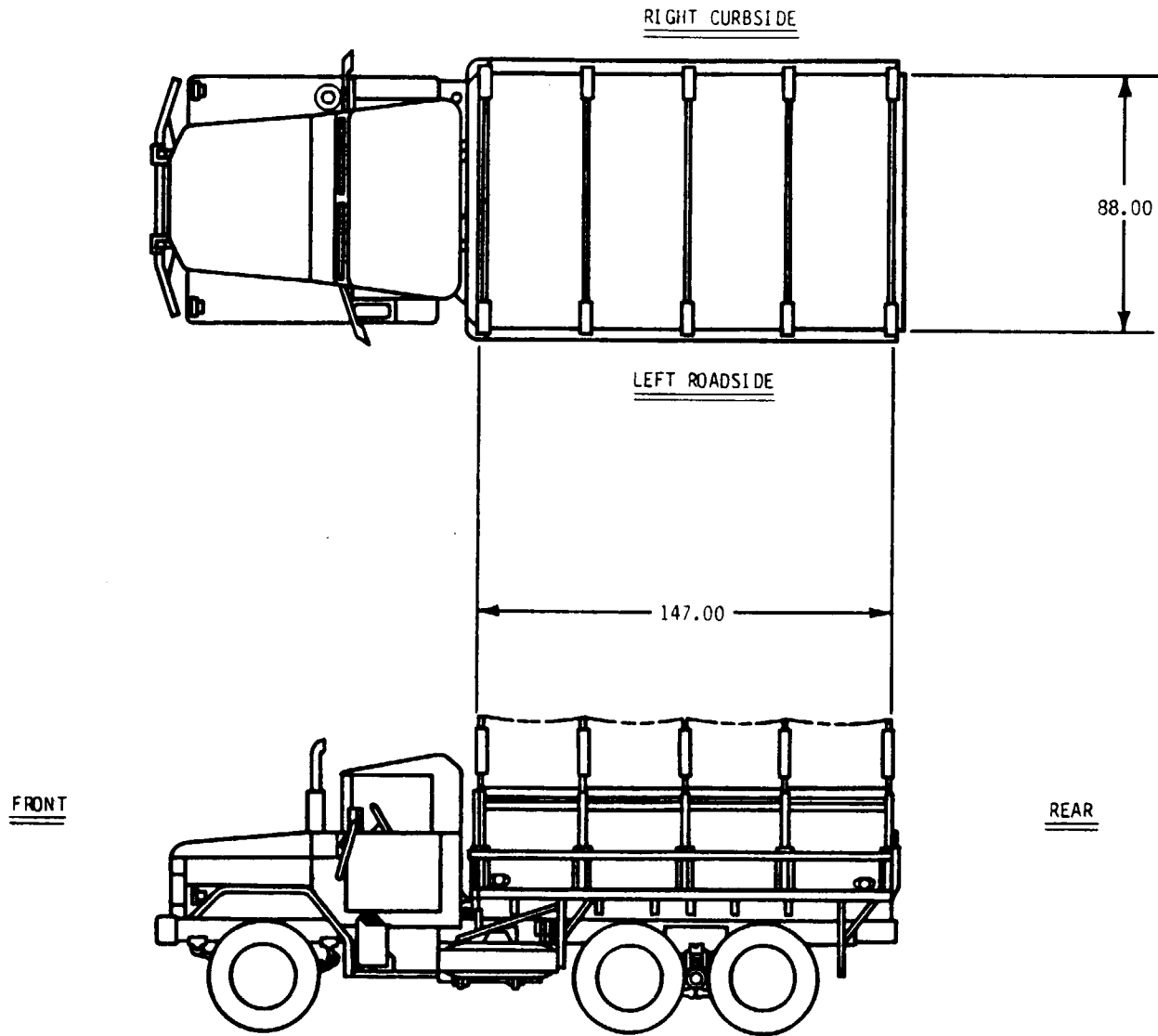

Figure 6. M35A2 Cargo Truck, Units 2 and 3.

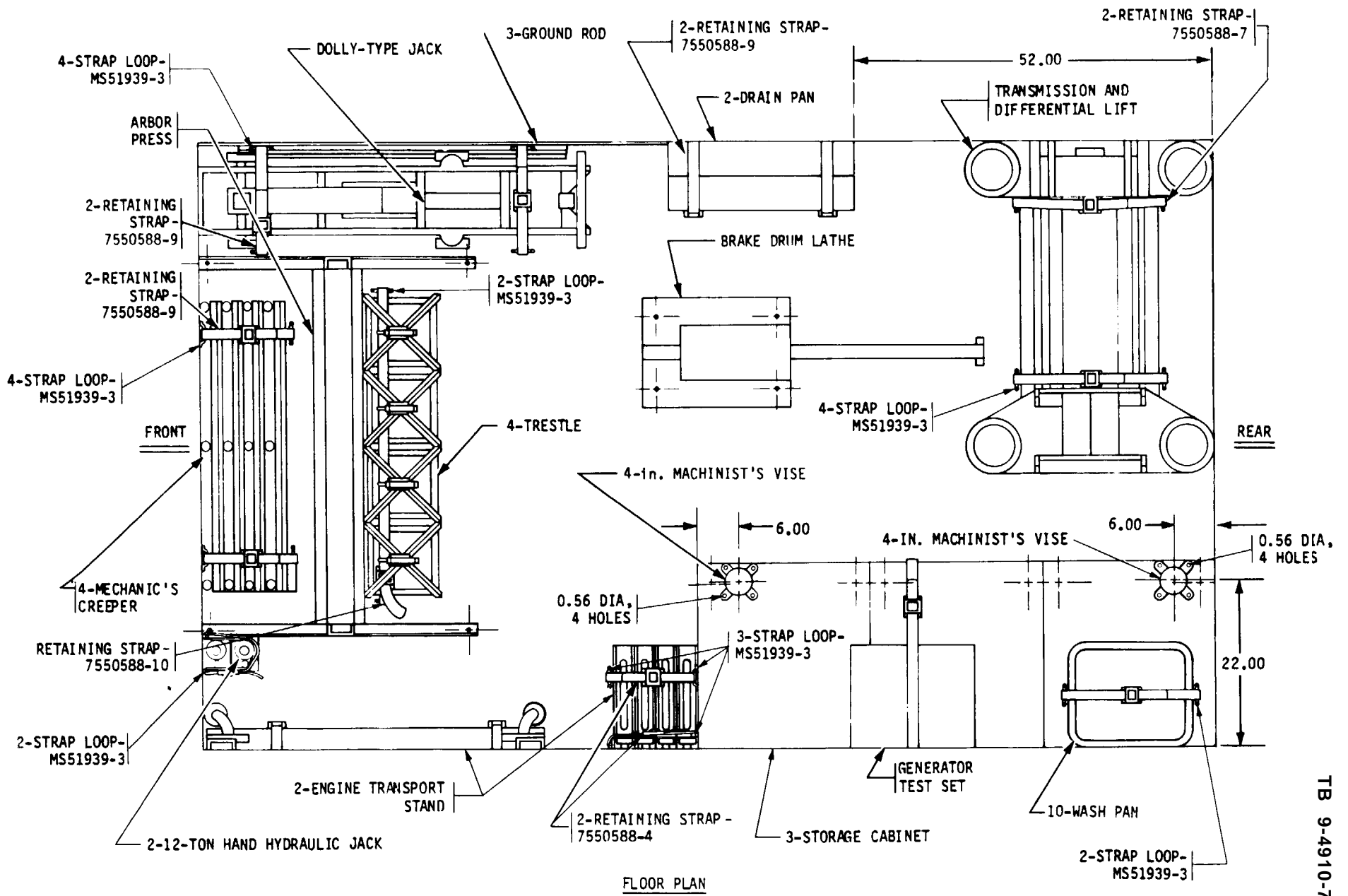

Figure 7. Components to be Mounted, Unit 2, M35A2, Floor Plan.

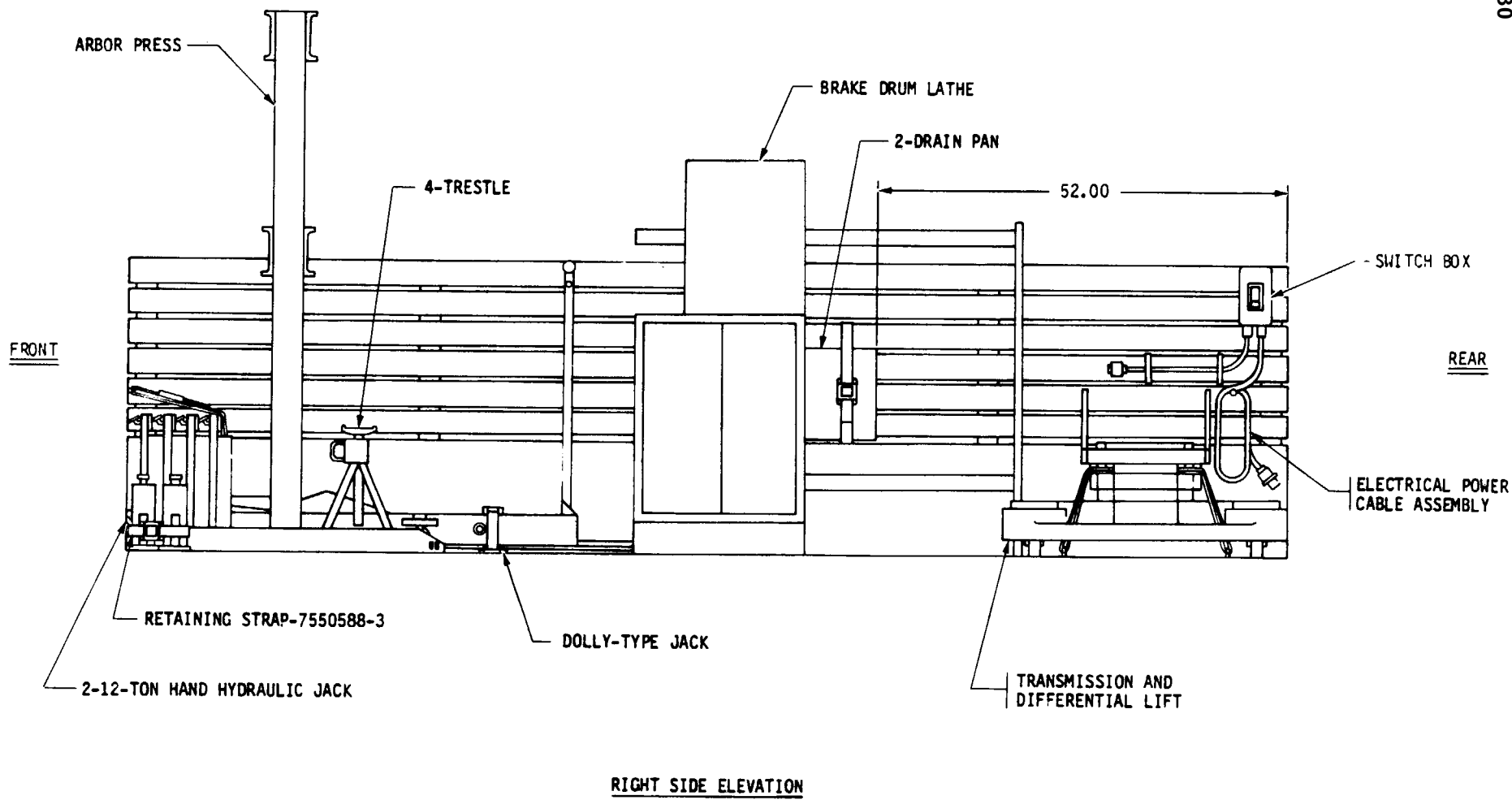

Figure 8. Components to be Mounted, Unit 2, M35A2, Right Side Elevation.

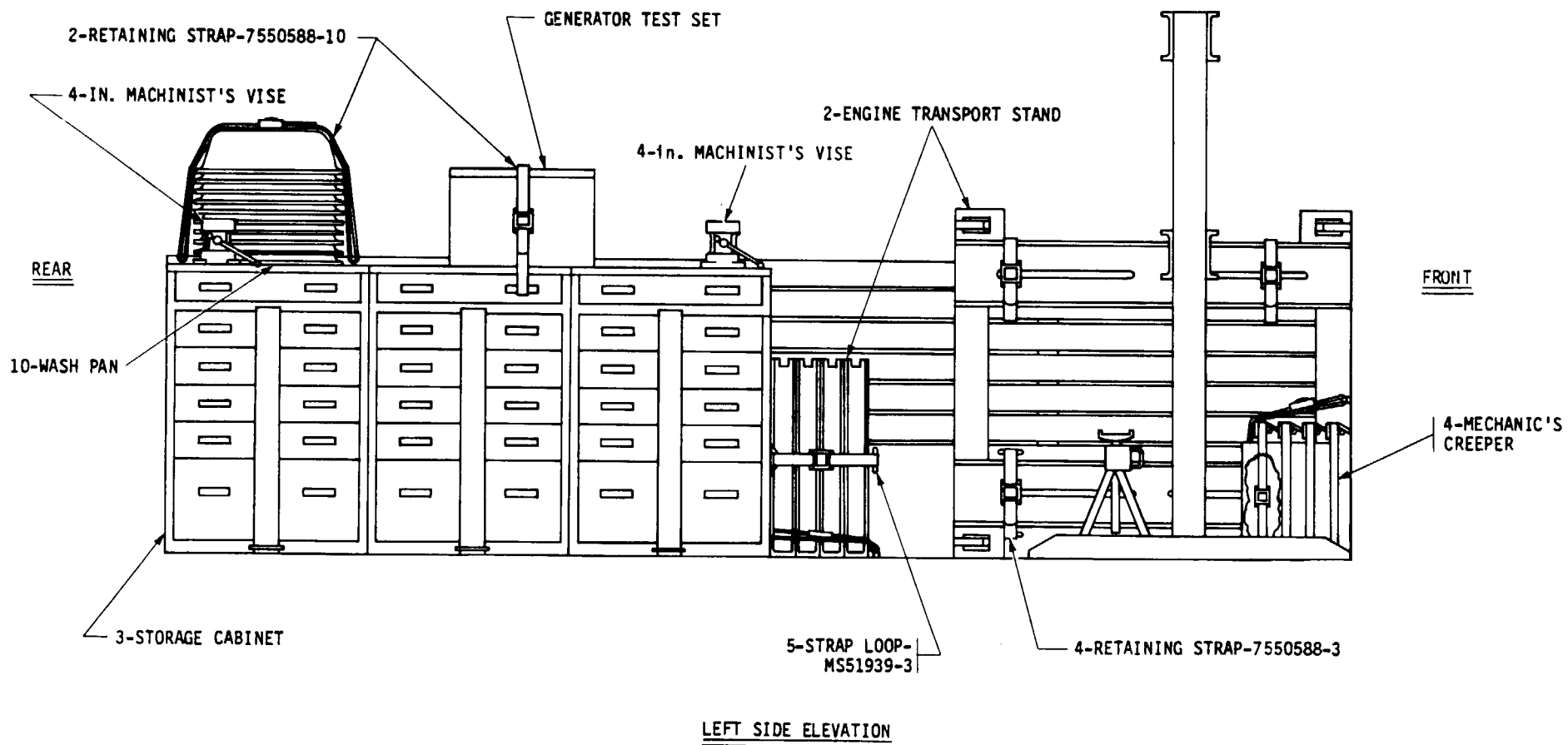

Figure 9. Components to be Mounted, Unit 2, M35A2, Left Side Elevation.

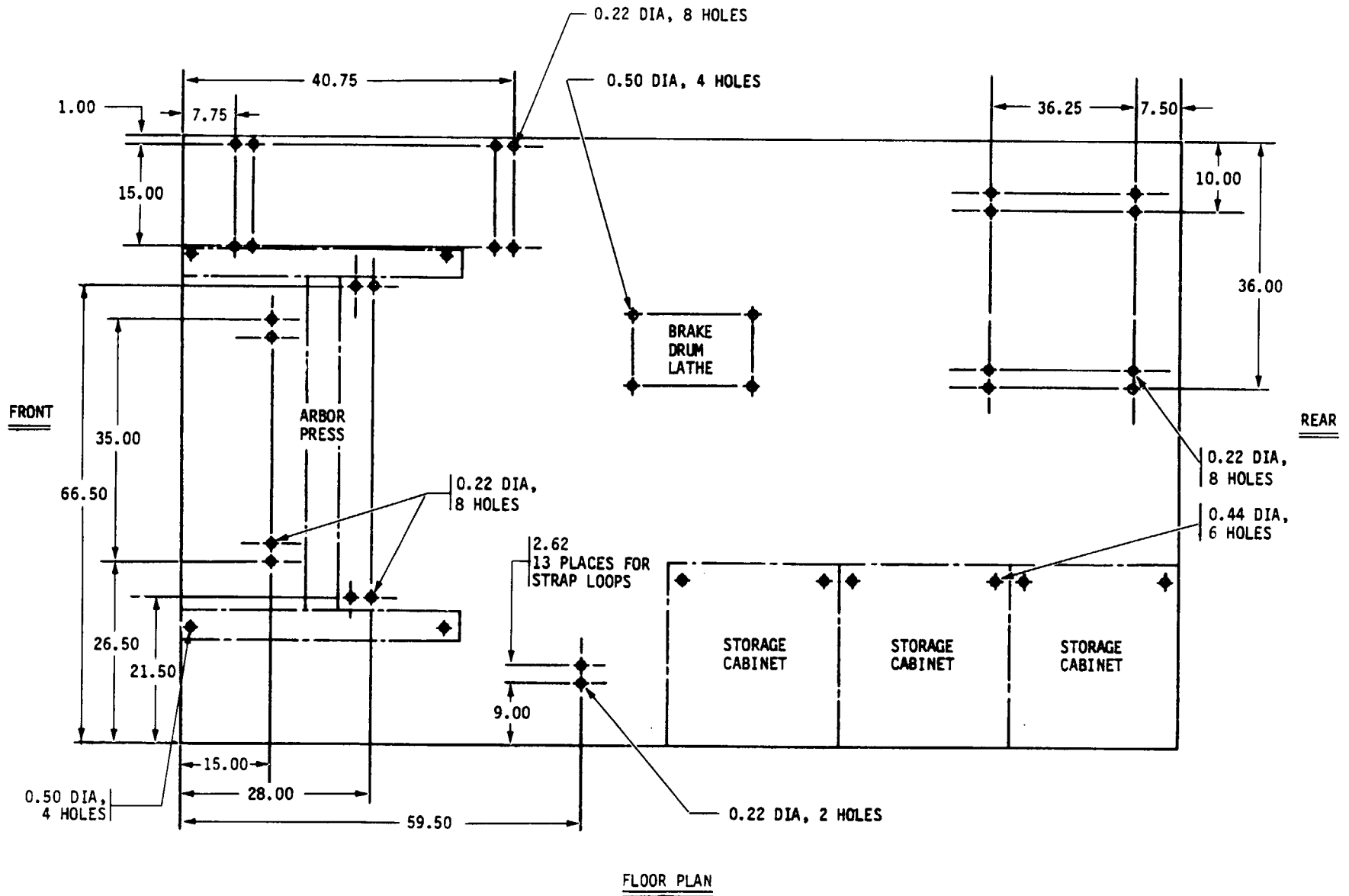

Figure 10. Hole Dimensions for Mounting Holes and Strap Loops, Unit 2, M35A2, Floor Plan.

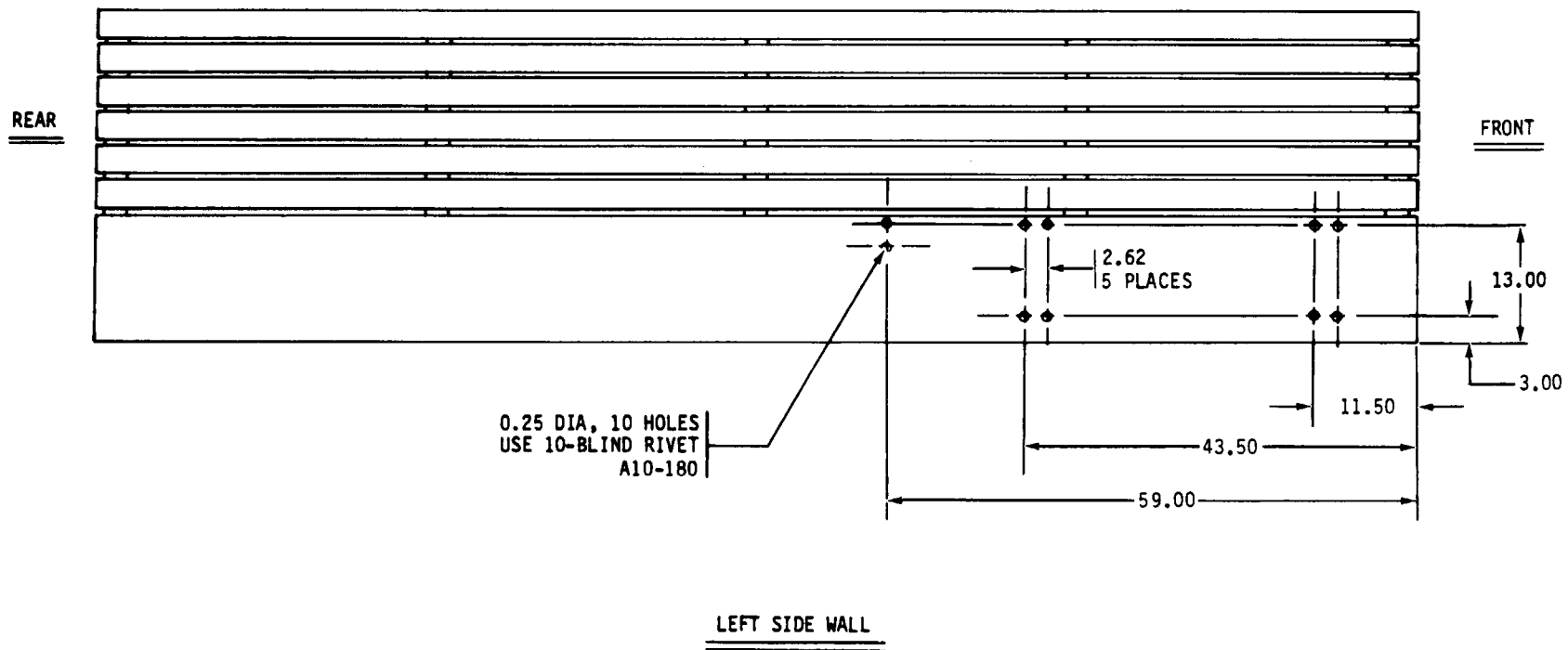

Figure 11. Hole Dimensions and Locations for Blind Rivet Nuts and Strap Loops in Left Side Wall, Unit 2, M35A2.

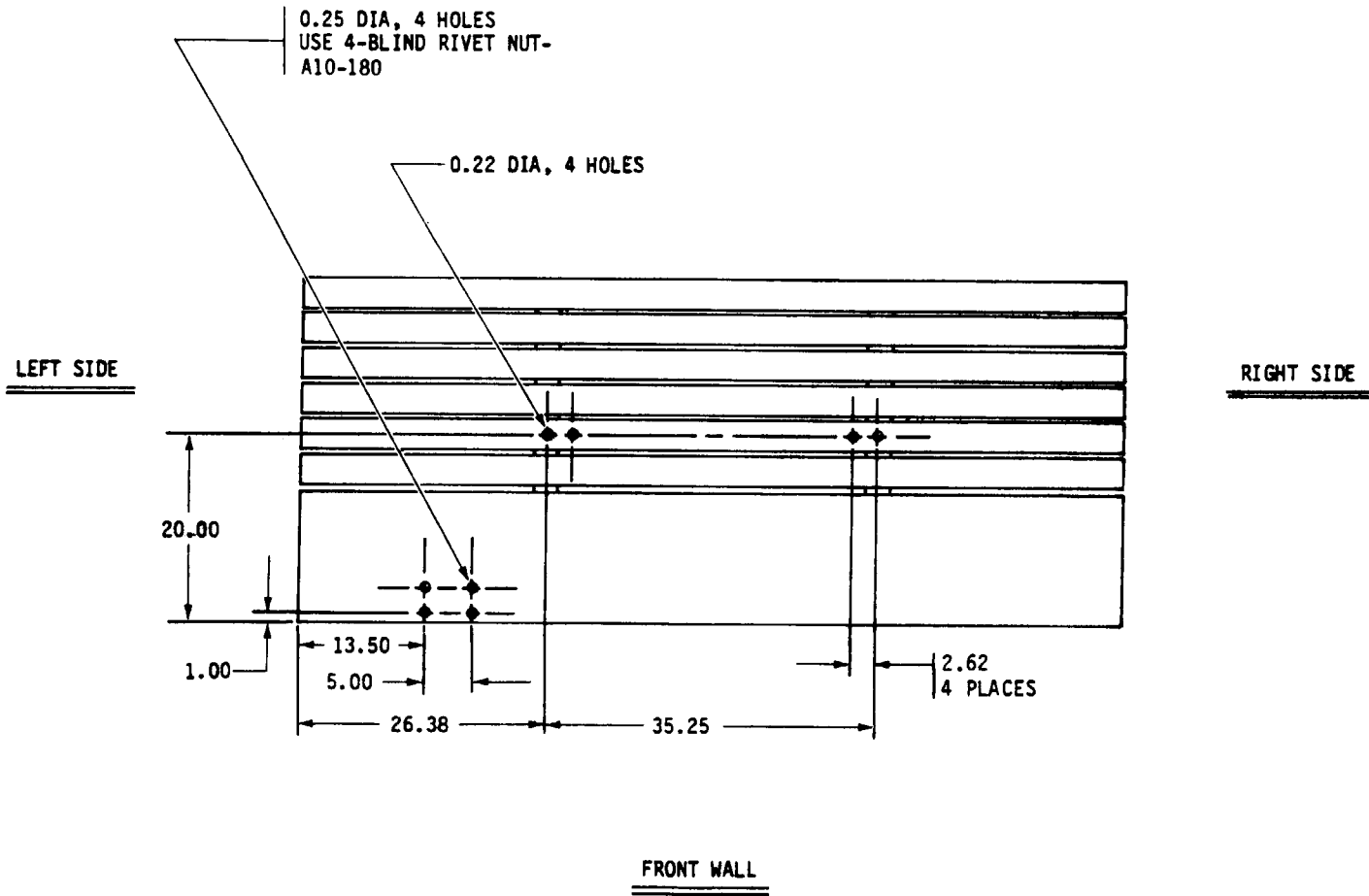
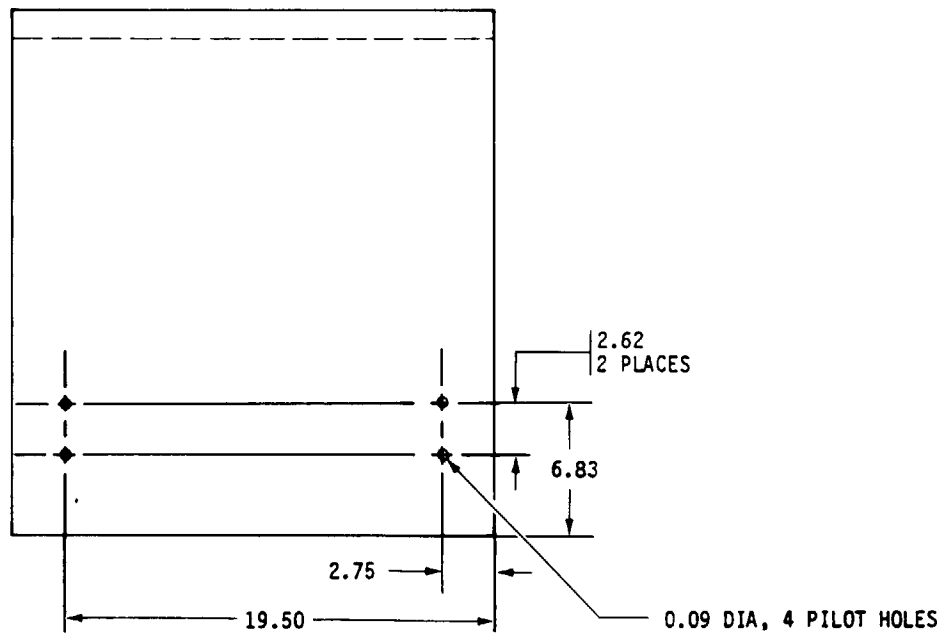

Figure 12. Hole Dimensions for Blind Rivet Nuts and Strap Loops in Front Wall, Unit 2, M35A2.

FRONT OF CABINET



TOP VIEW CABINET

Figure 13. Hole Dimensions for Cabinet Top Strap Loops, Unit 2, M35A2.

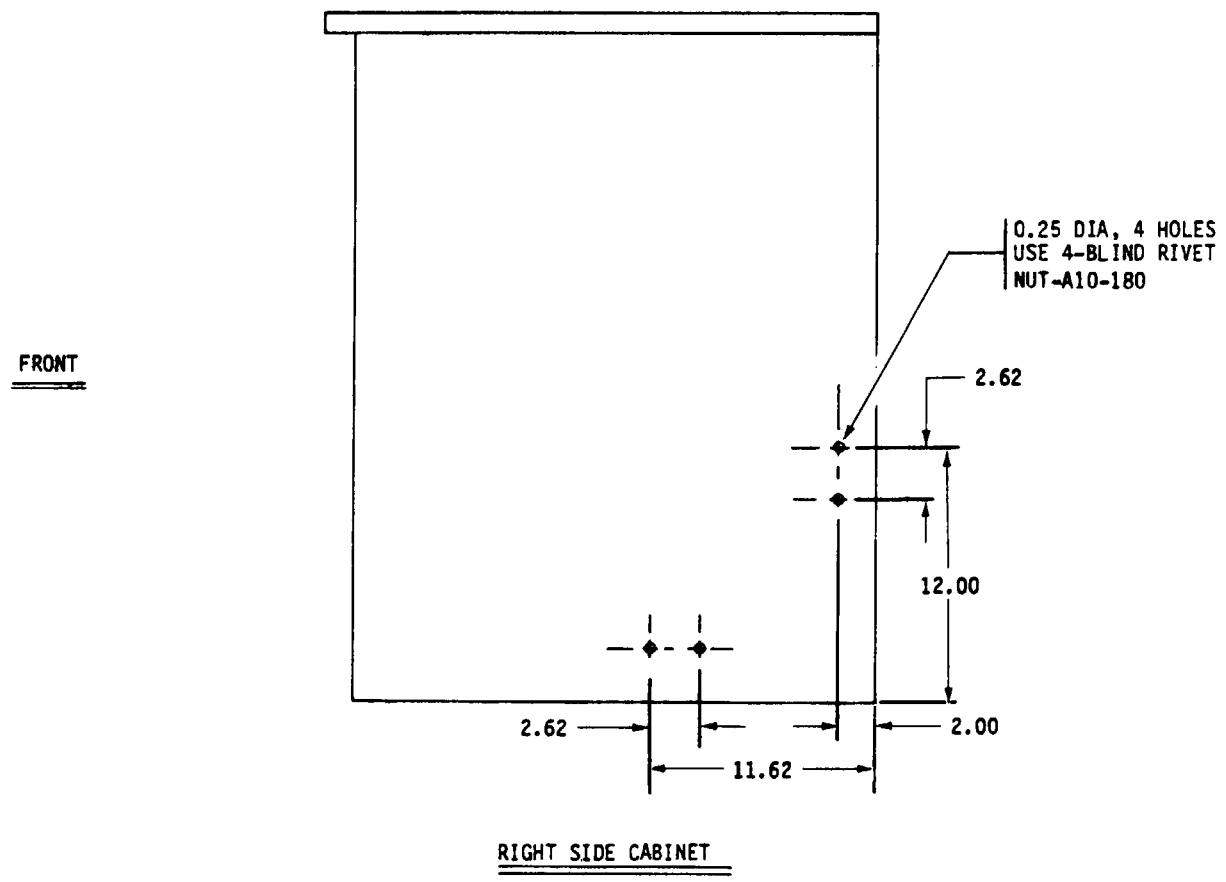

Figure 14. Hole Dimensions for Blind Rivet Nuts, Unit 2, M35A2, Cabinet Side.

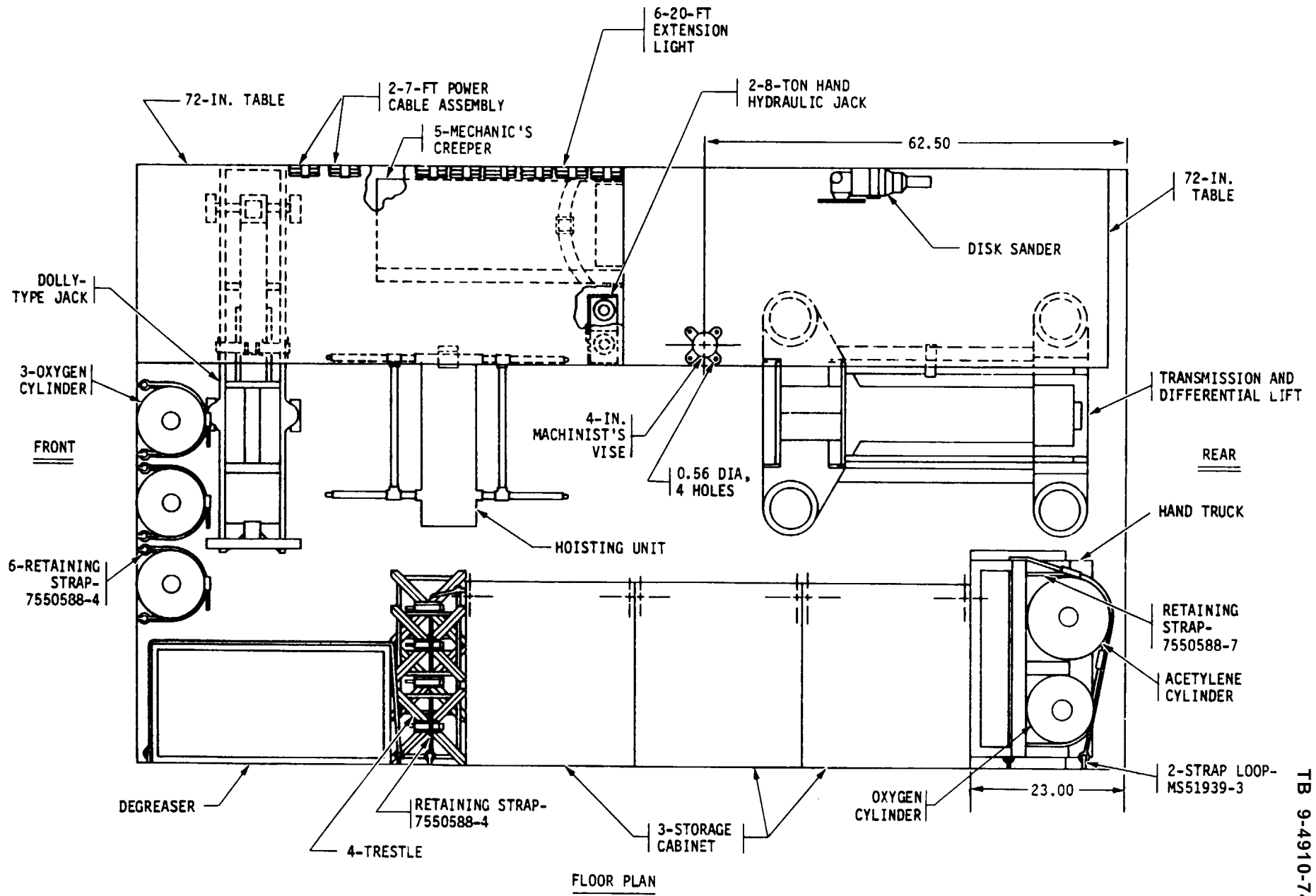

Figure 15. Components to be Mounted, Unit 3, M35A2, Floor Plan.

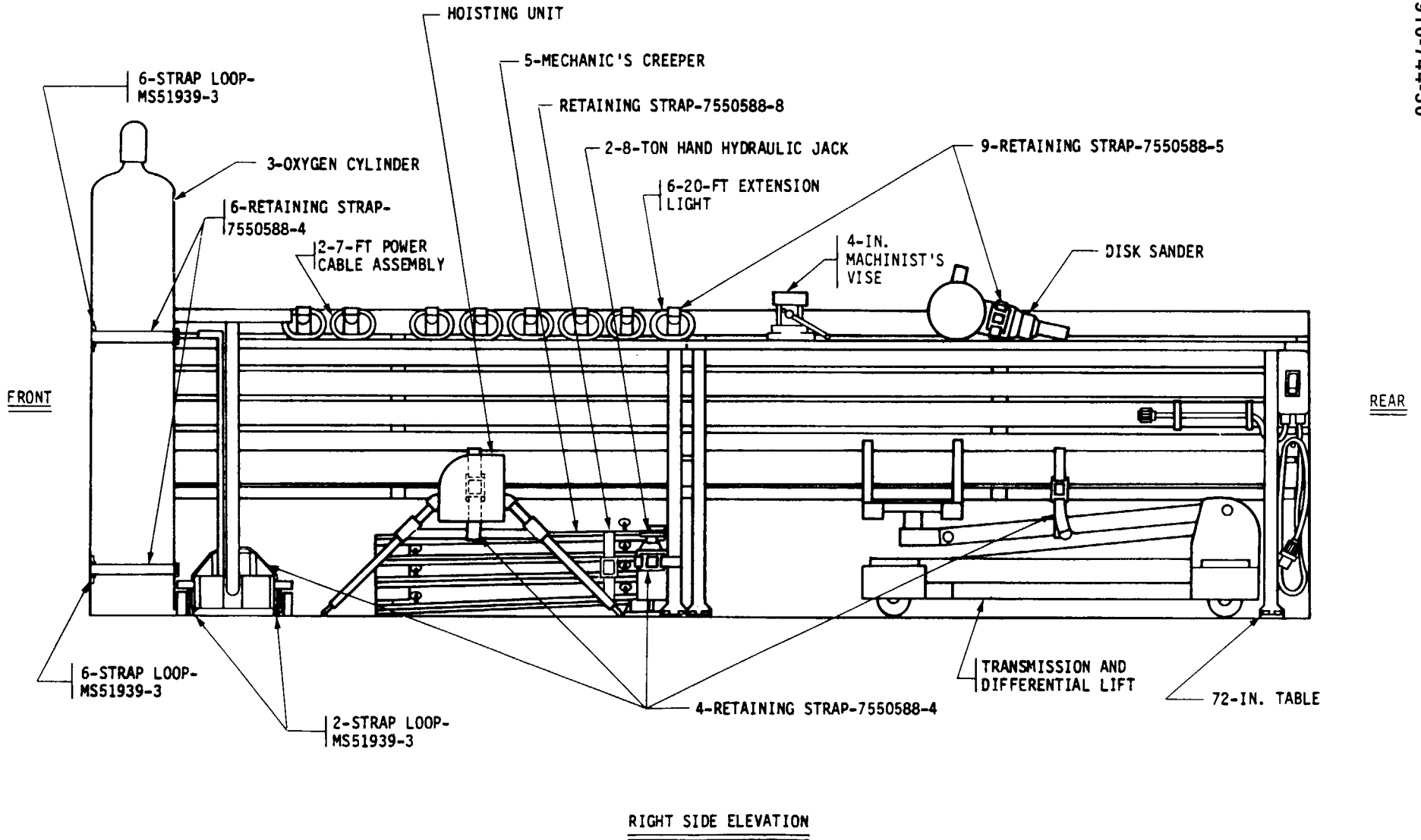

Figure 16. Components to be Mounted, Unit 3, M35A2, Right Side Elevation.

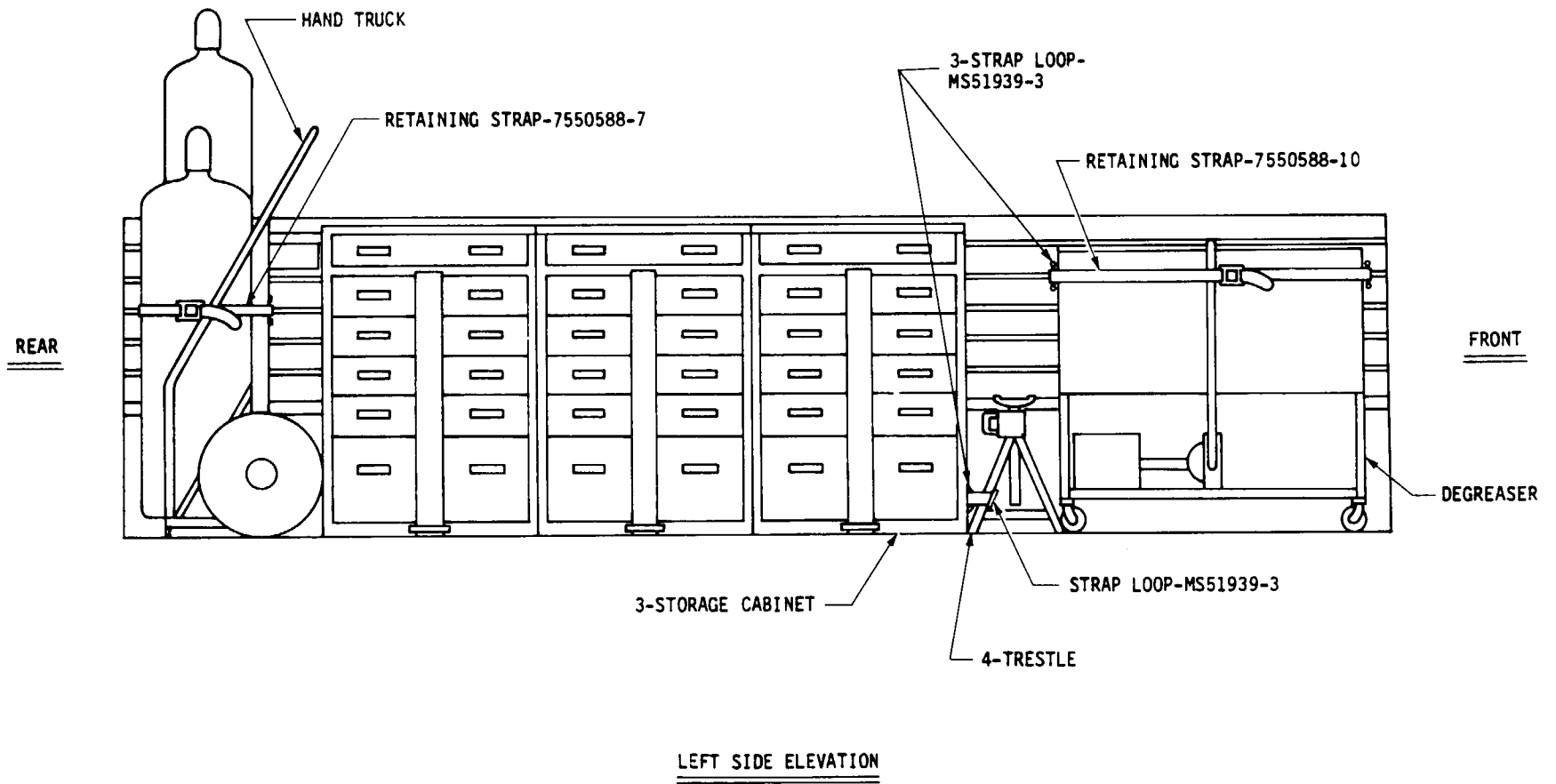

Figure 17. Components to be Mounted, Unit 3, M35A2, Left Side Elevation.

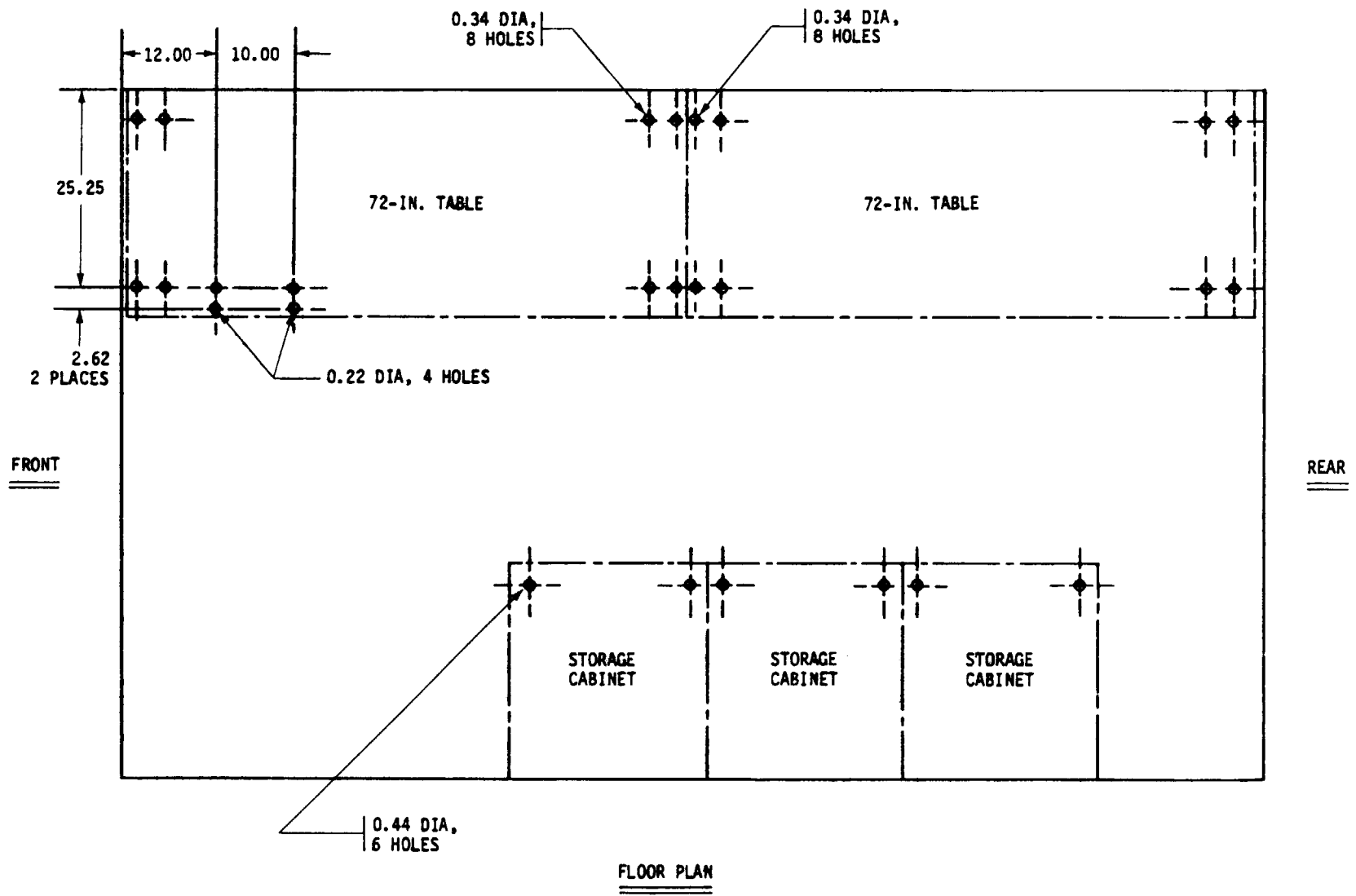

Figure 18. Hole Dimensions for Mounting Holes and Strap Loops, Unit 3, M35A2, Floor Plan.

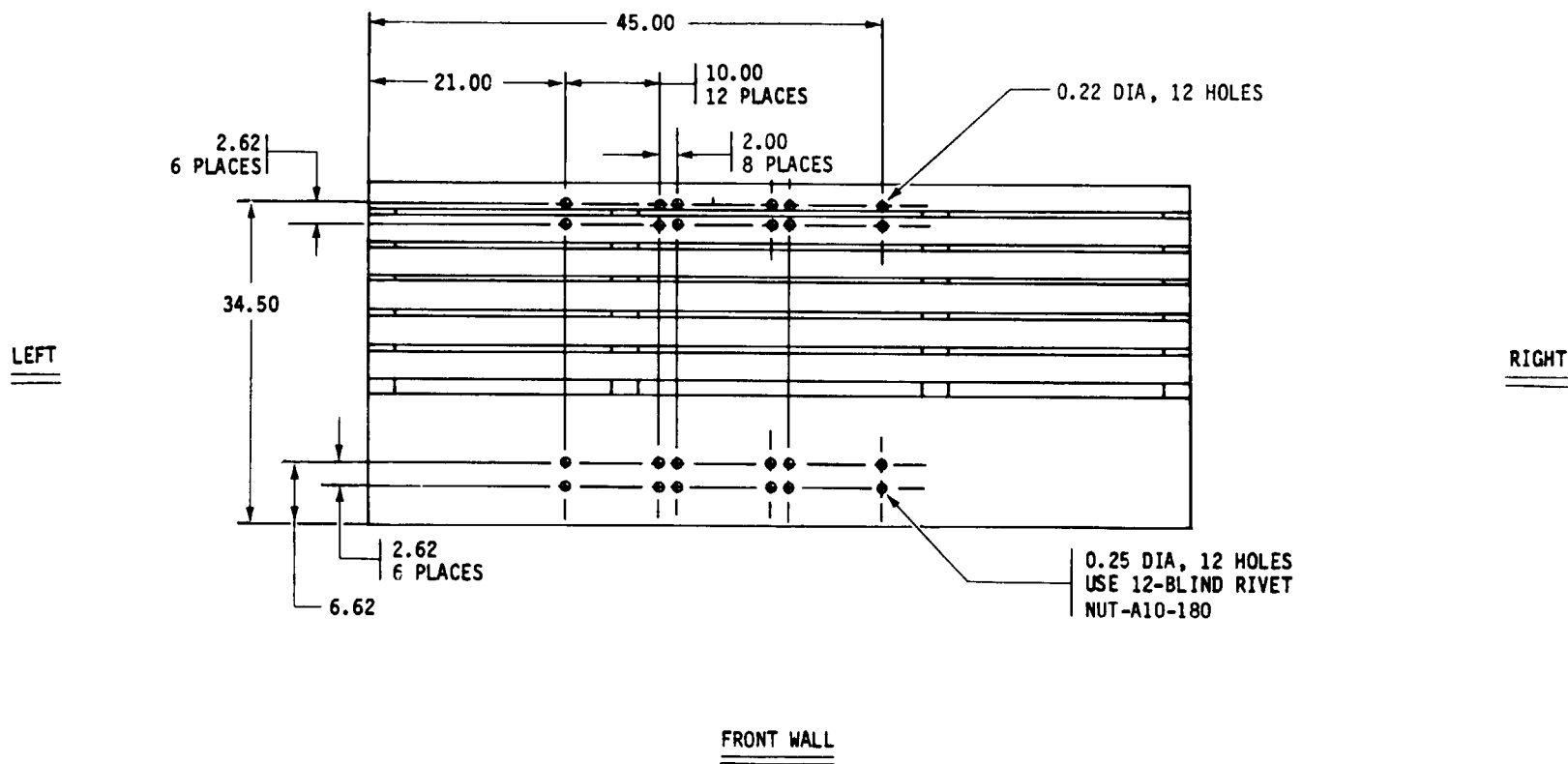

Figure 19. Hole Dimensions and Locations for Blind Rivet Nuts and Strap Loops, Unit 3, M35A2, Front Wall.

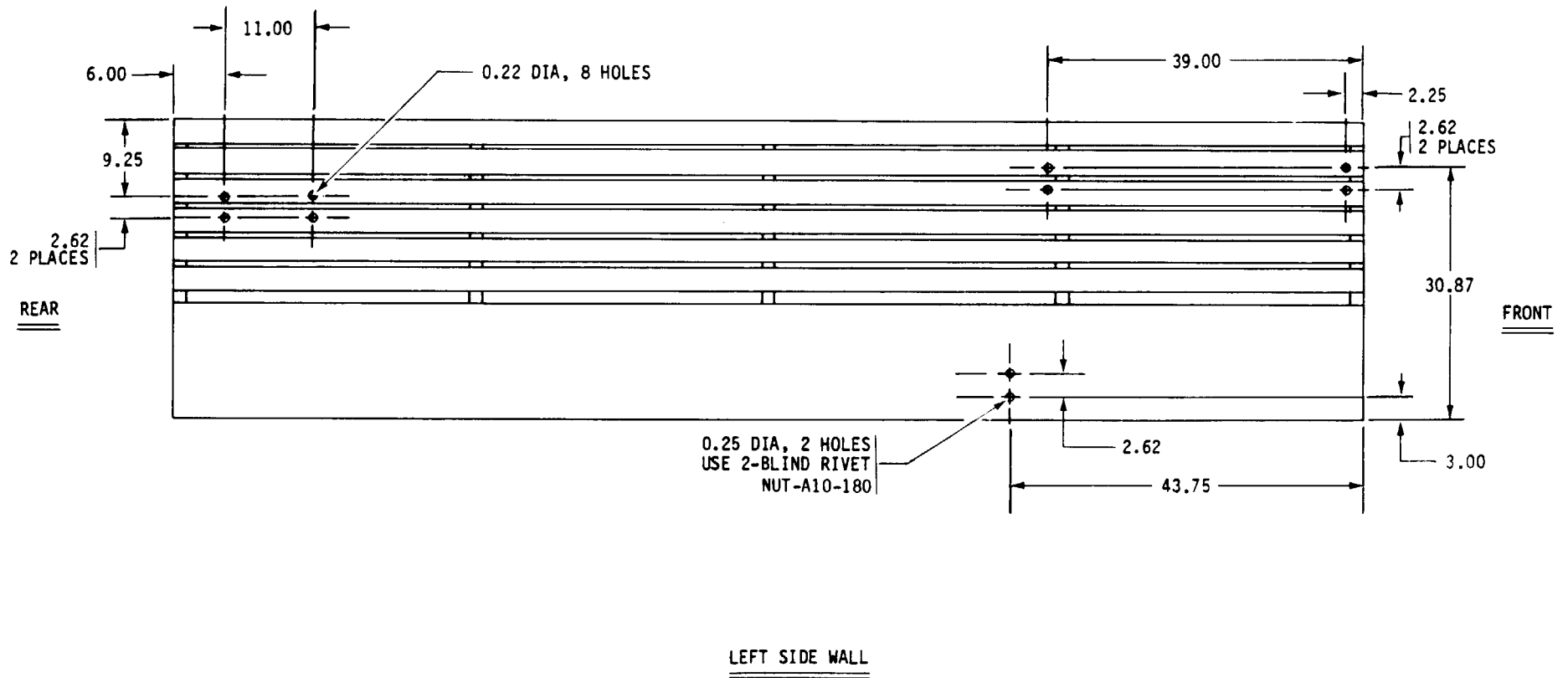

Figure 20. Hole Dimensions and Locations for Blind Rivet Nuts and Strap Loops, Unit 3, M35A2, Left Side Wall.

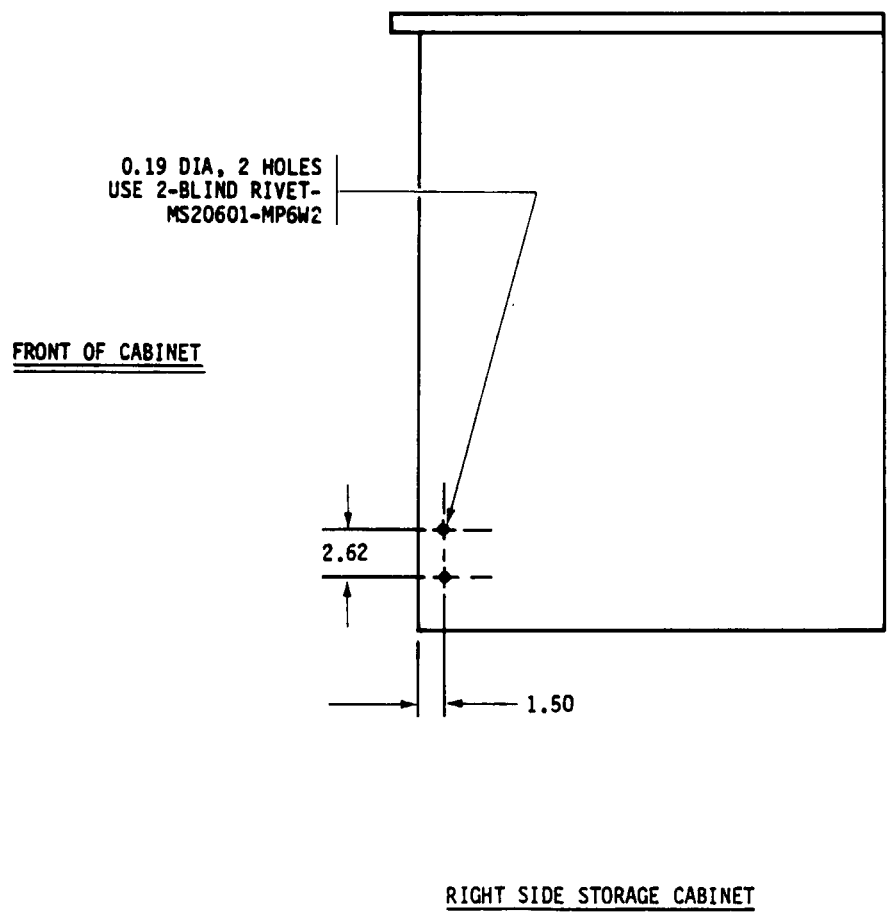

Figure 21. Hole Dimensions for Blind Rivets, Unit 3, M35A2, Cabinet Side.

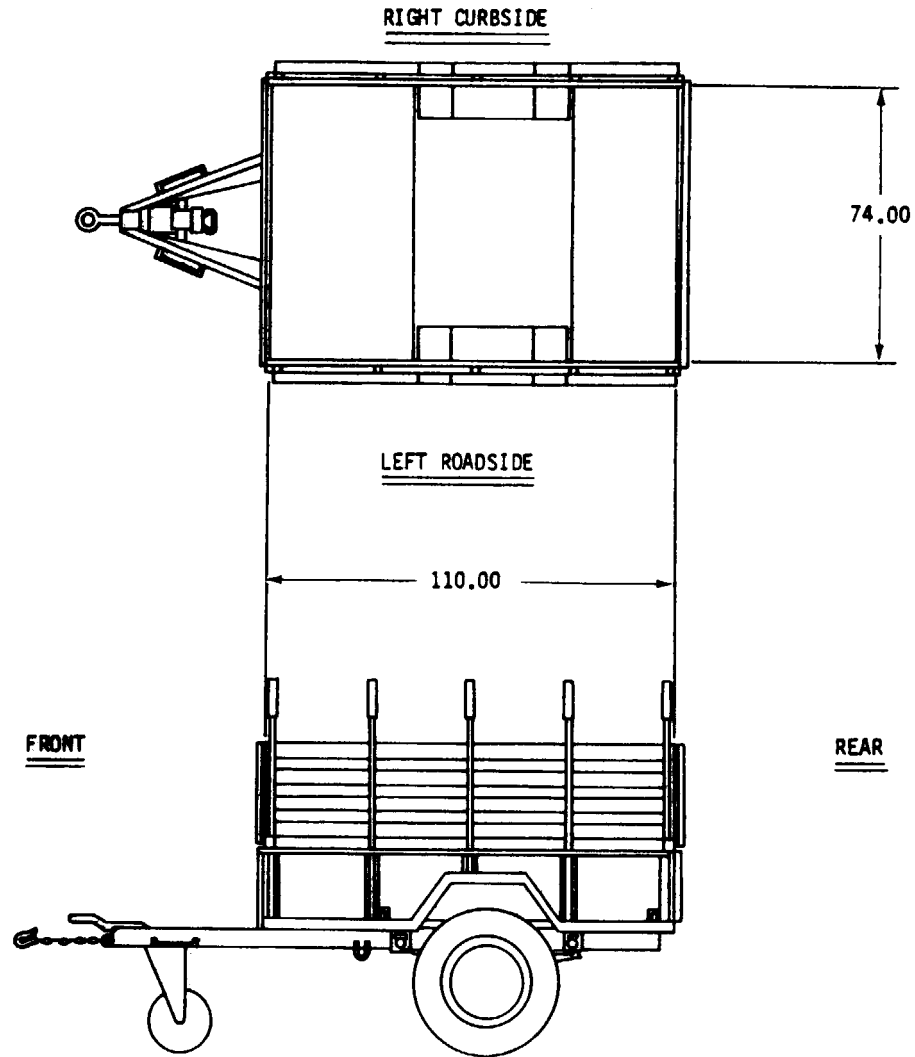

Figure 22. M105A2 Cargo Trailer, Units 4, 5, and 6.

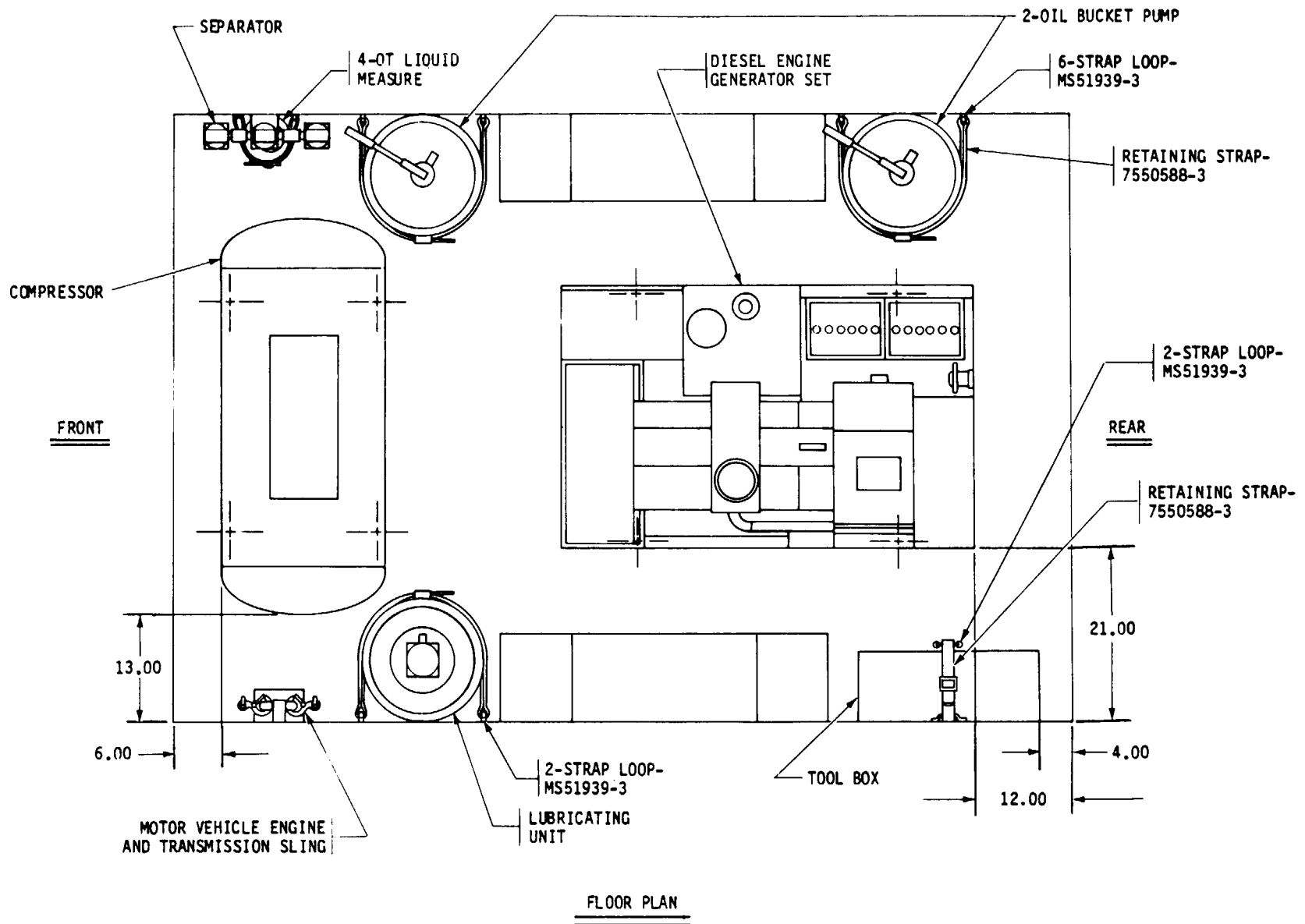

Figure 23. Components to be Mounted, Unit 4, M105A2, Floor Plan.

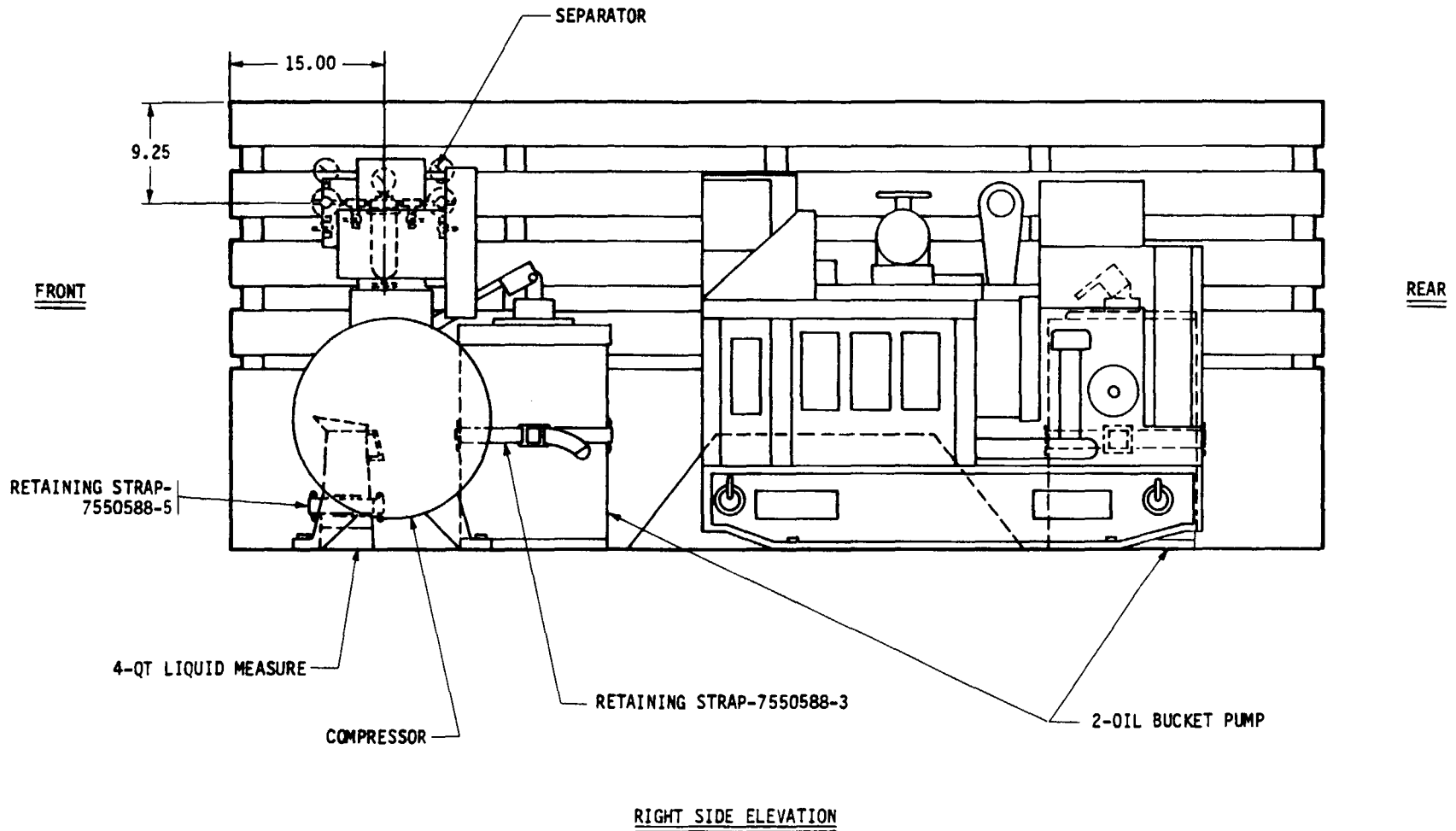

Figure 24. Components to be Mounted, Unit 4, M105A2, Right Side Elevation.

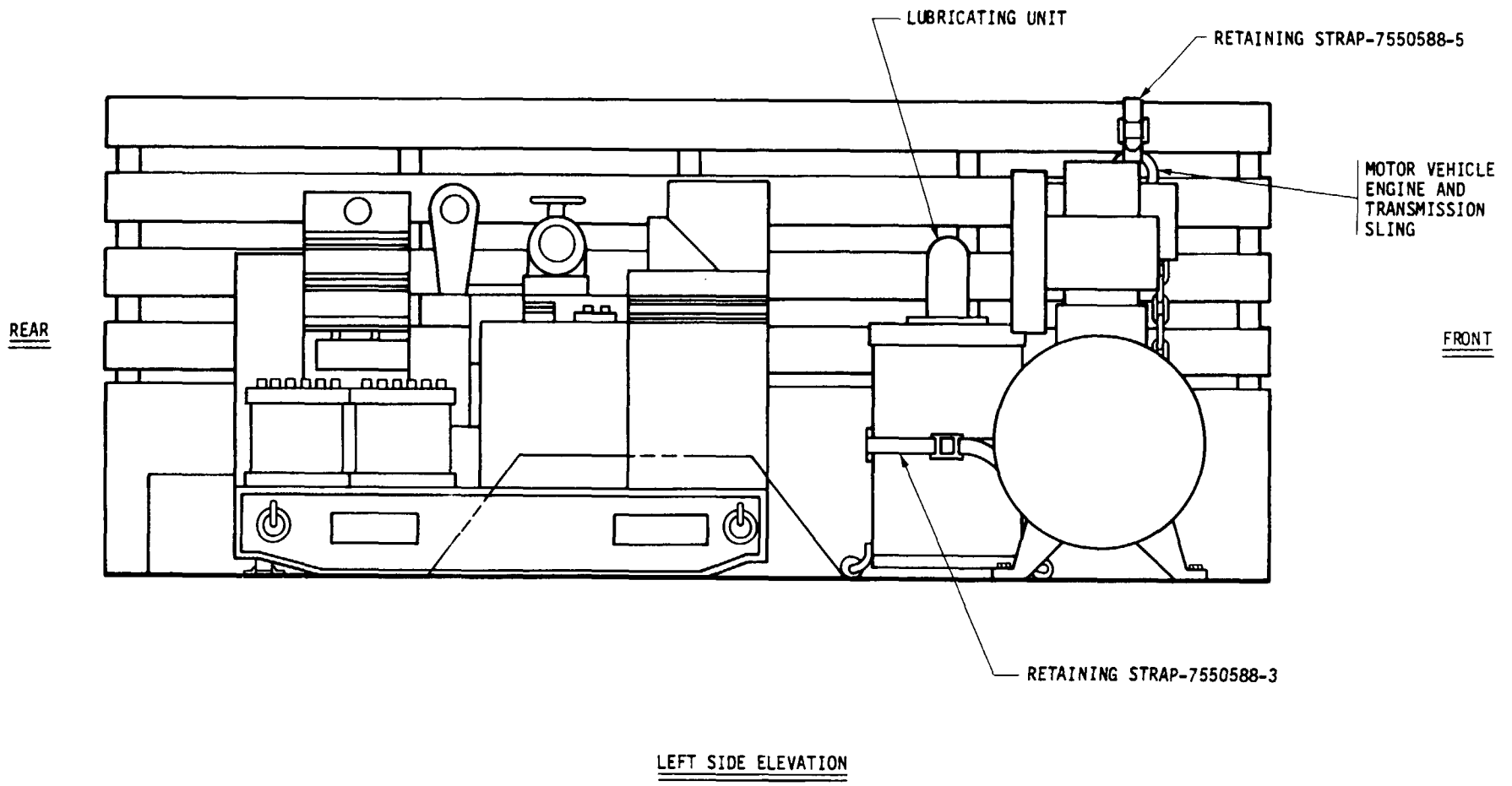

Figure 25. Components to be Mounted, Unit 4, M105A2, Left Side Elevation.

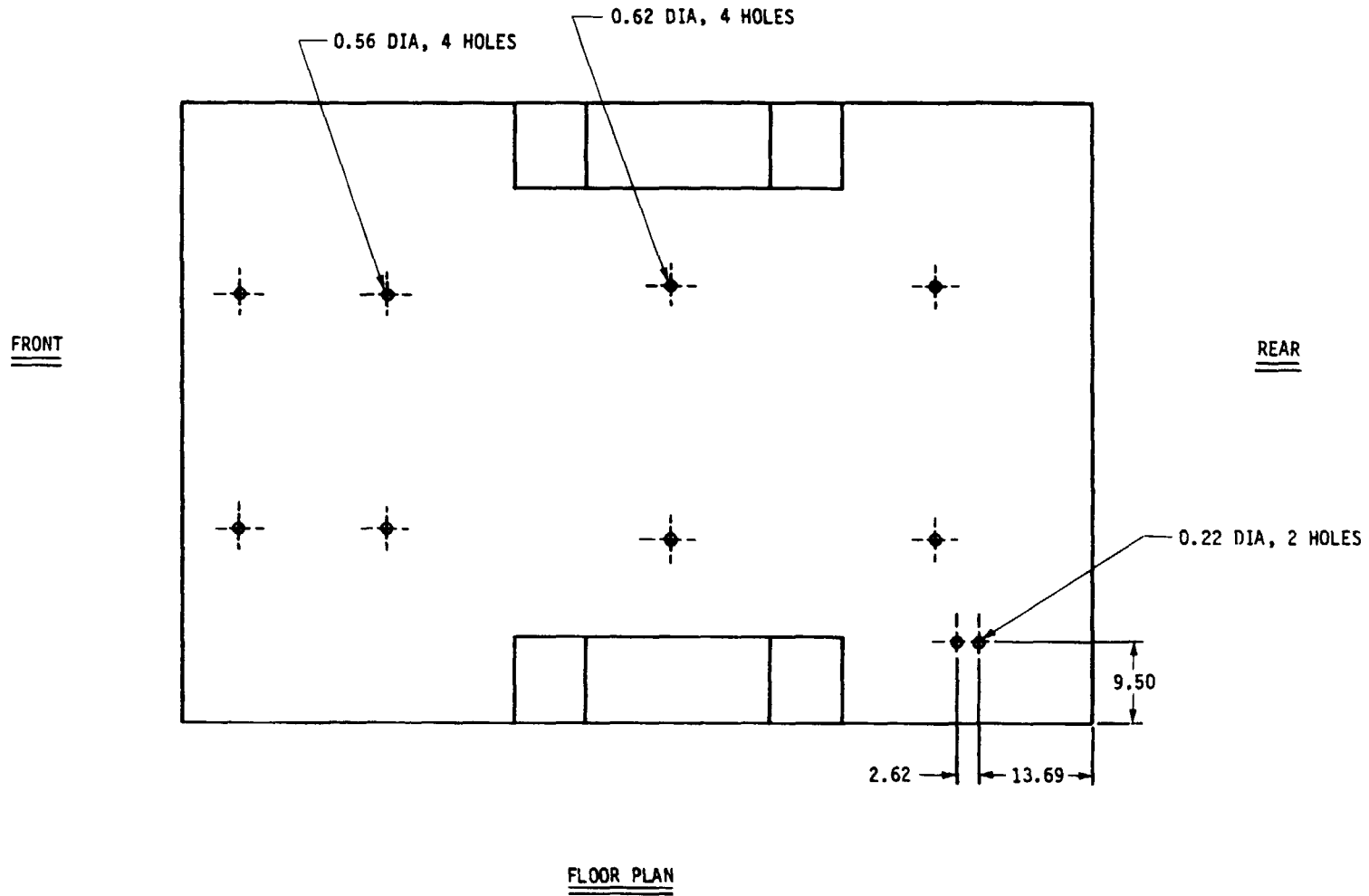

Figure 26. Hole Dimensions for Mounting Holes and Strap Loop, Unit 4, M105A2, Floor Plan.

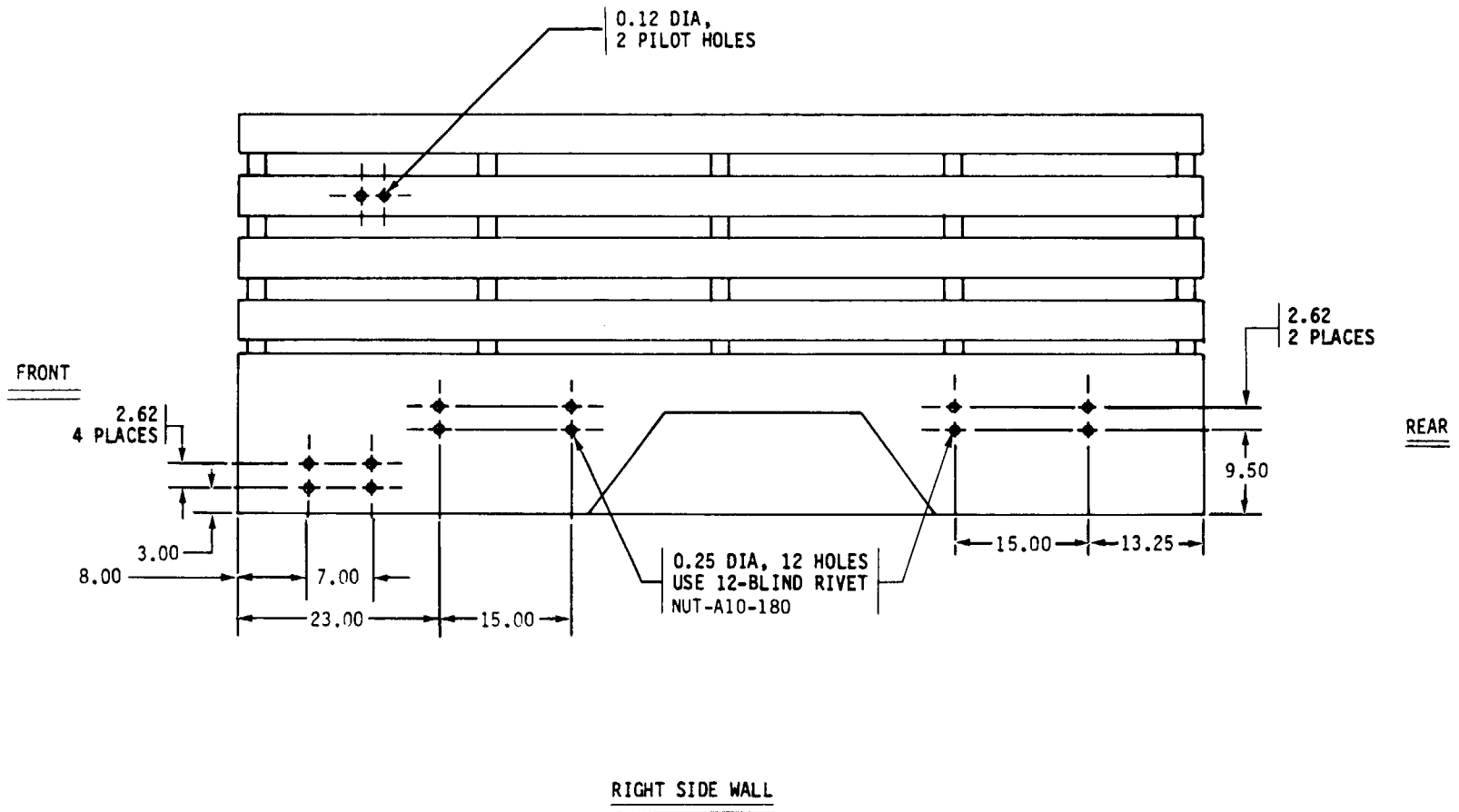

Figure 27. Hole Dimensions for Blind Rivet Nuts and Strap Loops in Right Side Wall, Unit 4, M105A2.

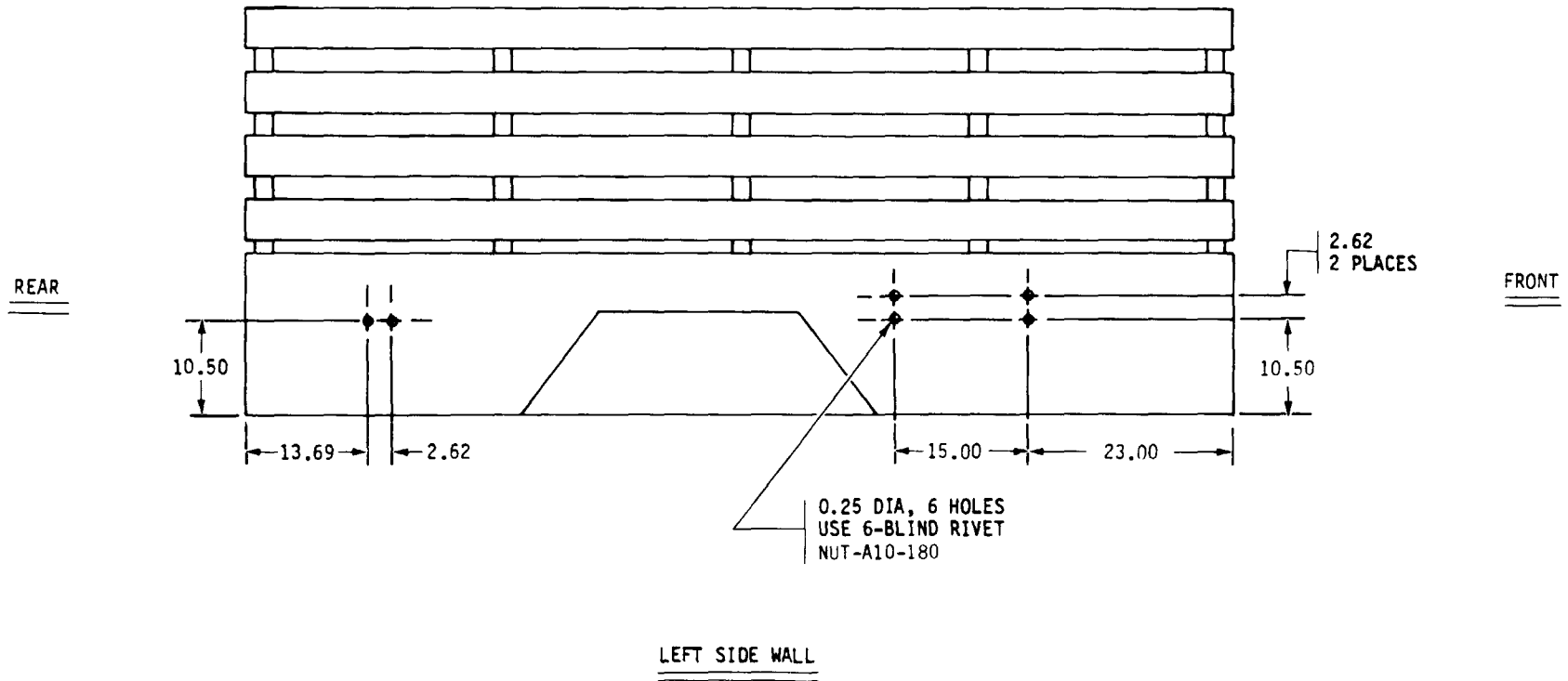

Figure 28. Hole Dimensions for Blind Rivet Nuts and Strap Loops in Left Side Wall, Unit 4, M105A2.

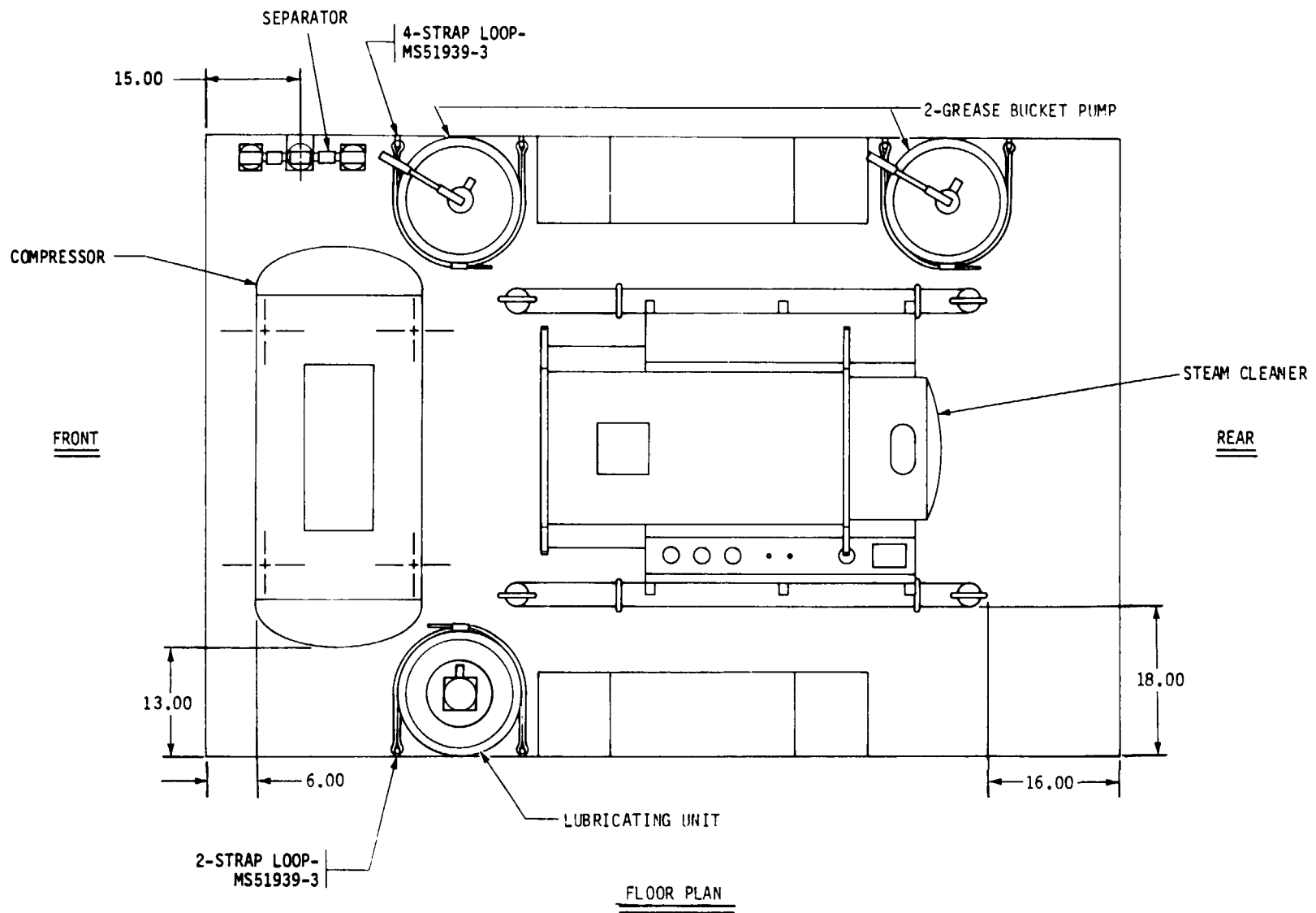

Figure 29. Components to be Mounted, Unit 5, M105A2, Floor Plan.

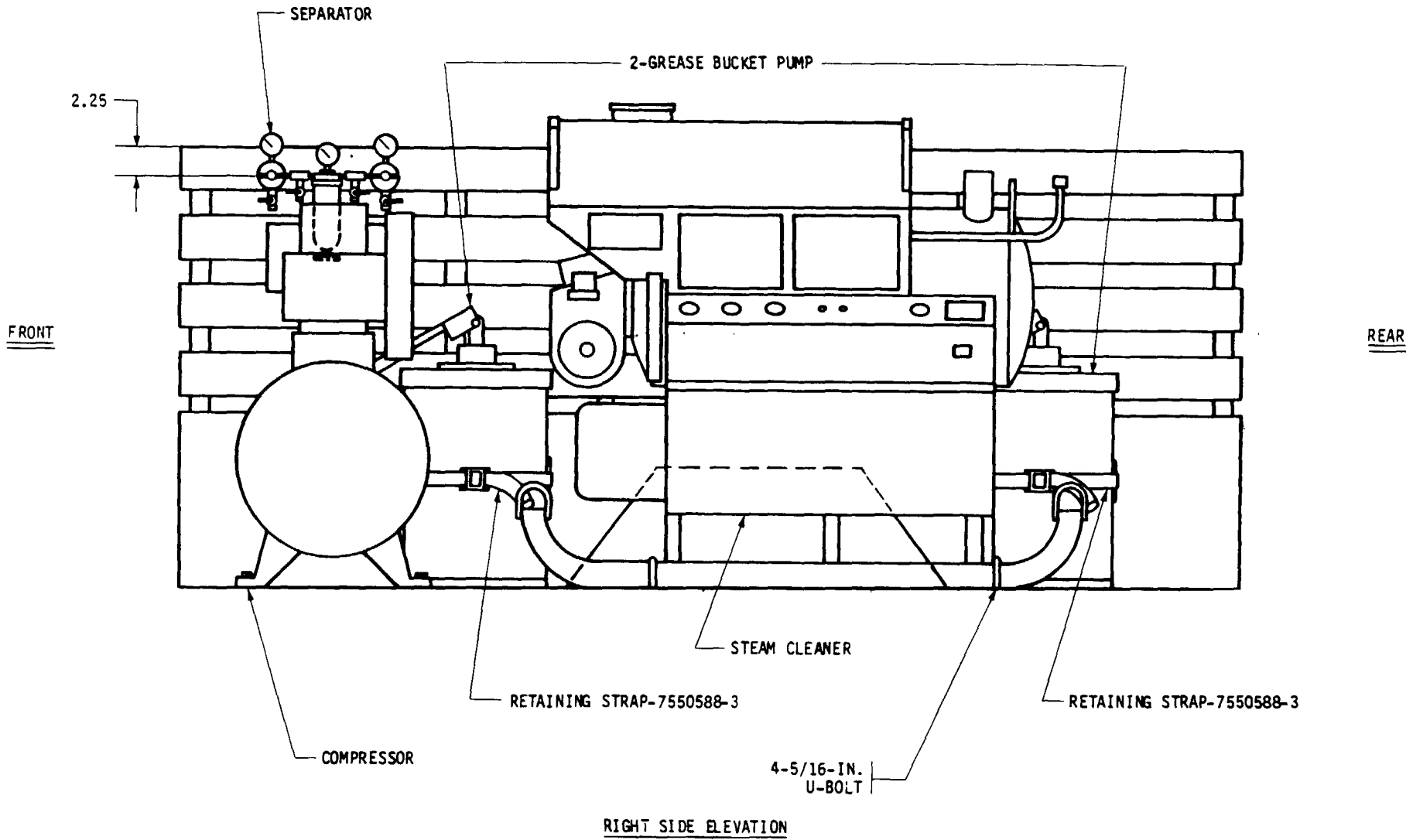

Figure 30. Components to be Mounted, Unit 5, M105A2, Right Side Elevation.

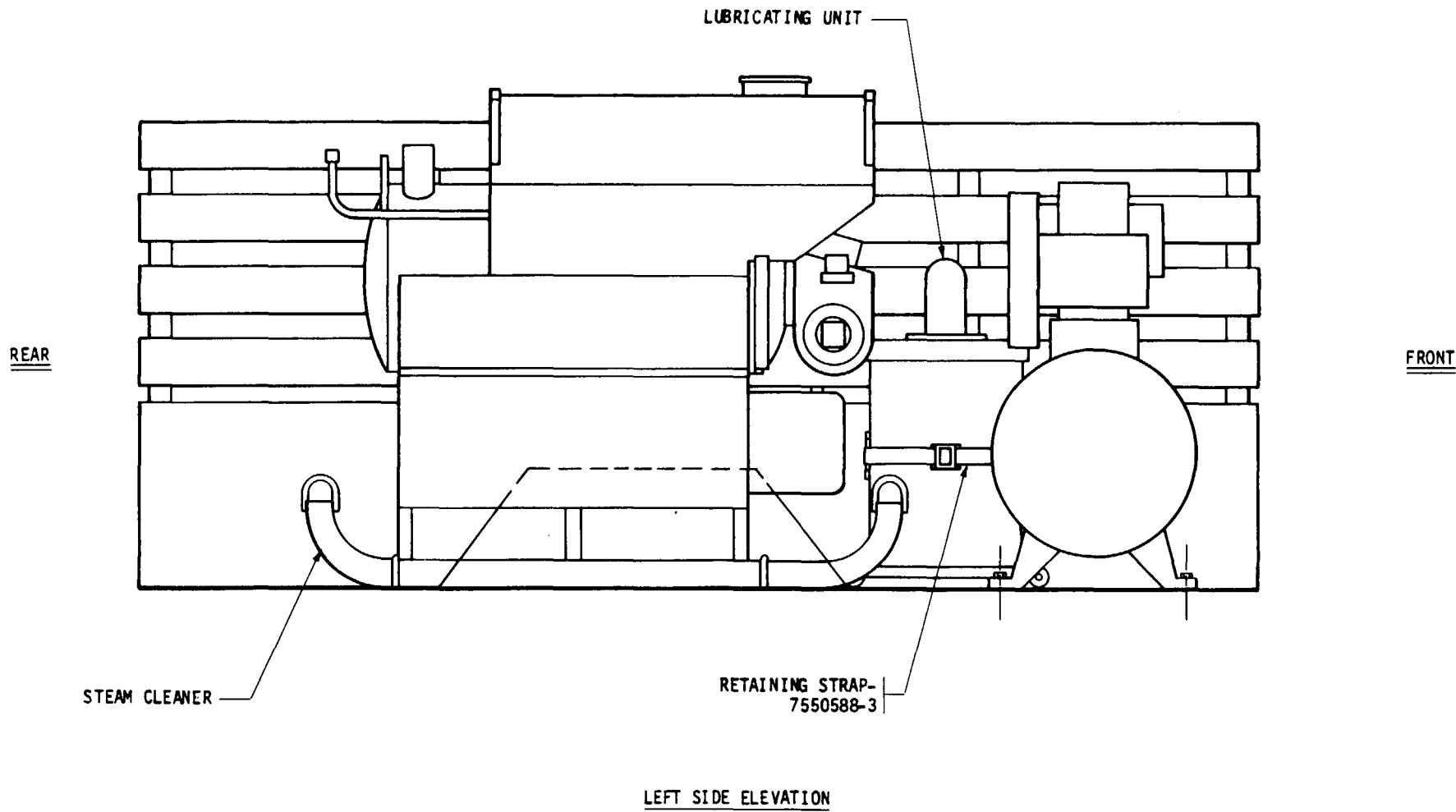

Figure 31. Components to be Mounted, Unit 5, M105A2, Left Side Elevation.

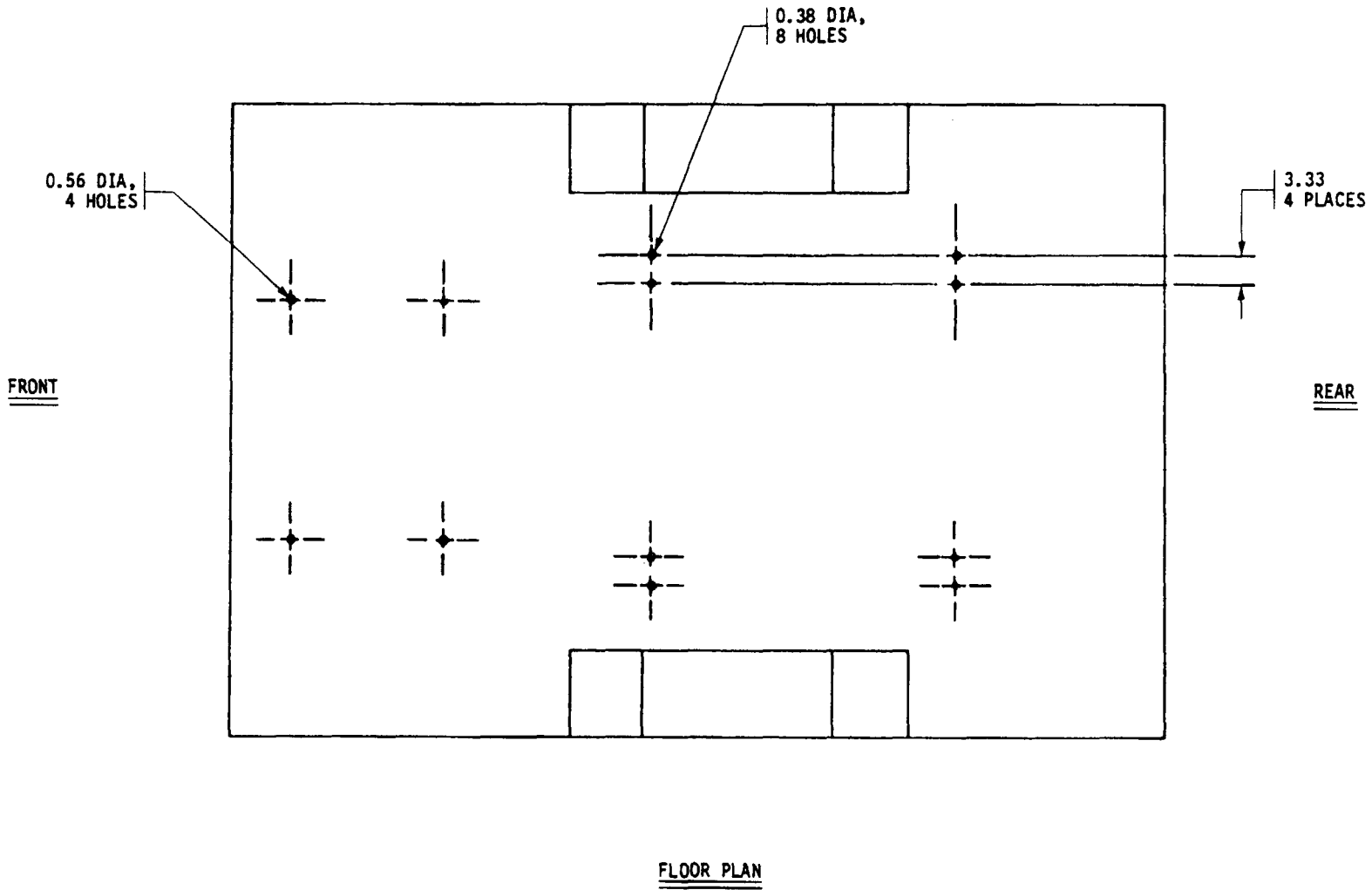
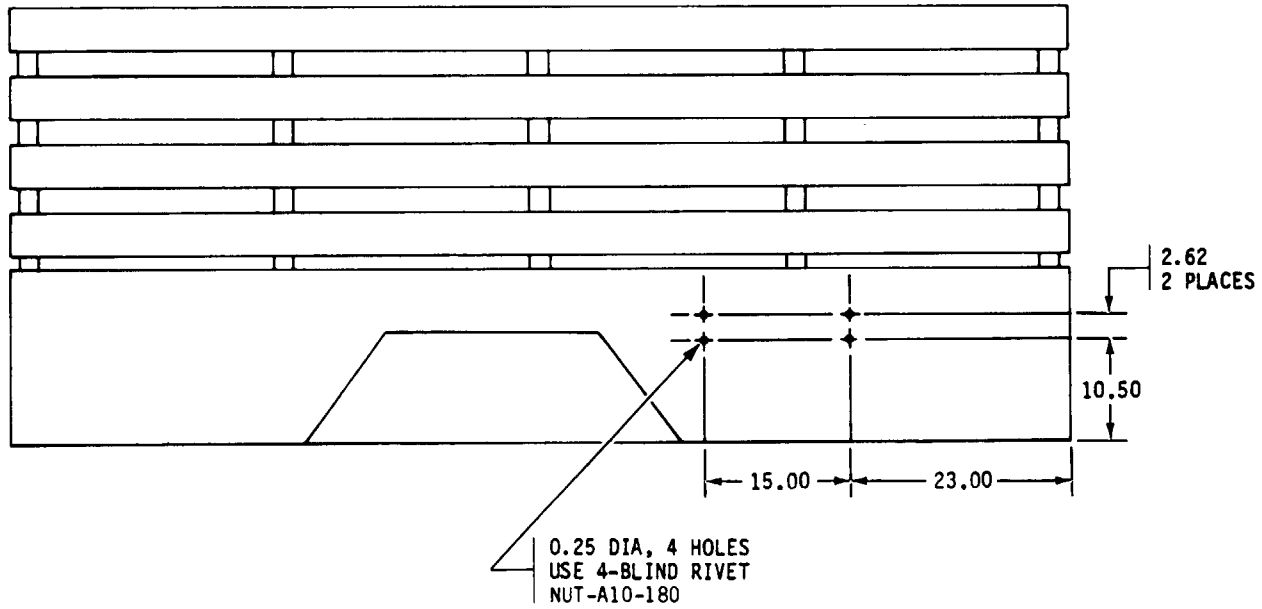

Figure 32. Hole Dimensions for Mounting Holes, Unit 5, M105A2, Floor Plan.

REAR



FRONT

LEFT SIDE WALL

Figure 33. Hole Dimensions for Blind Rivet Nuts and Strap Loops, Unit 5, M105A2, Left Side Wall.

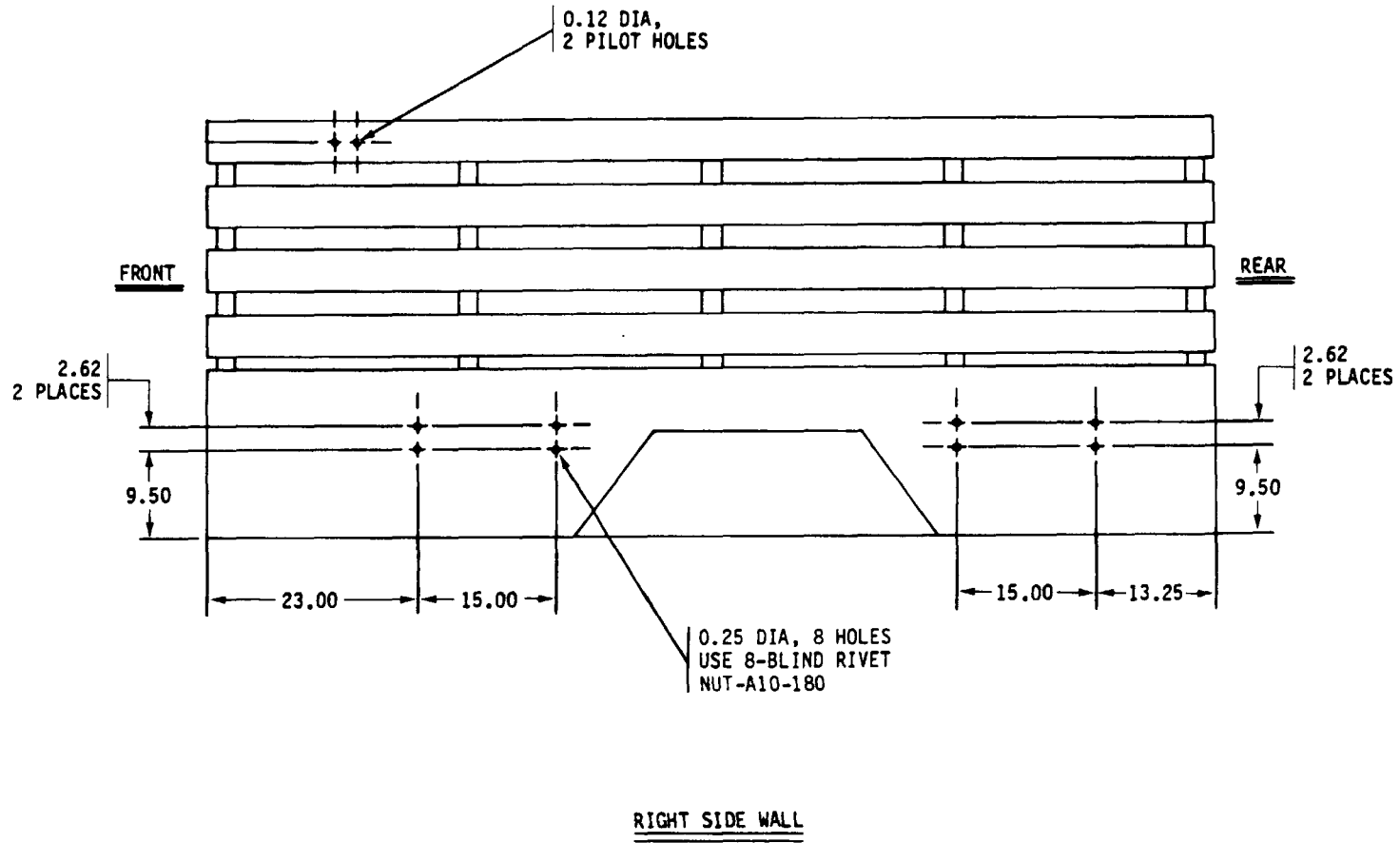

Figure 34. Hole Dimensions for Blind Rivet Nuts and Strap Loops, Unit 5, M105A2, Right Side Wall.

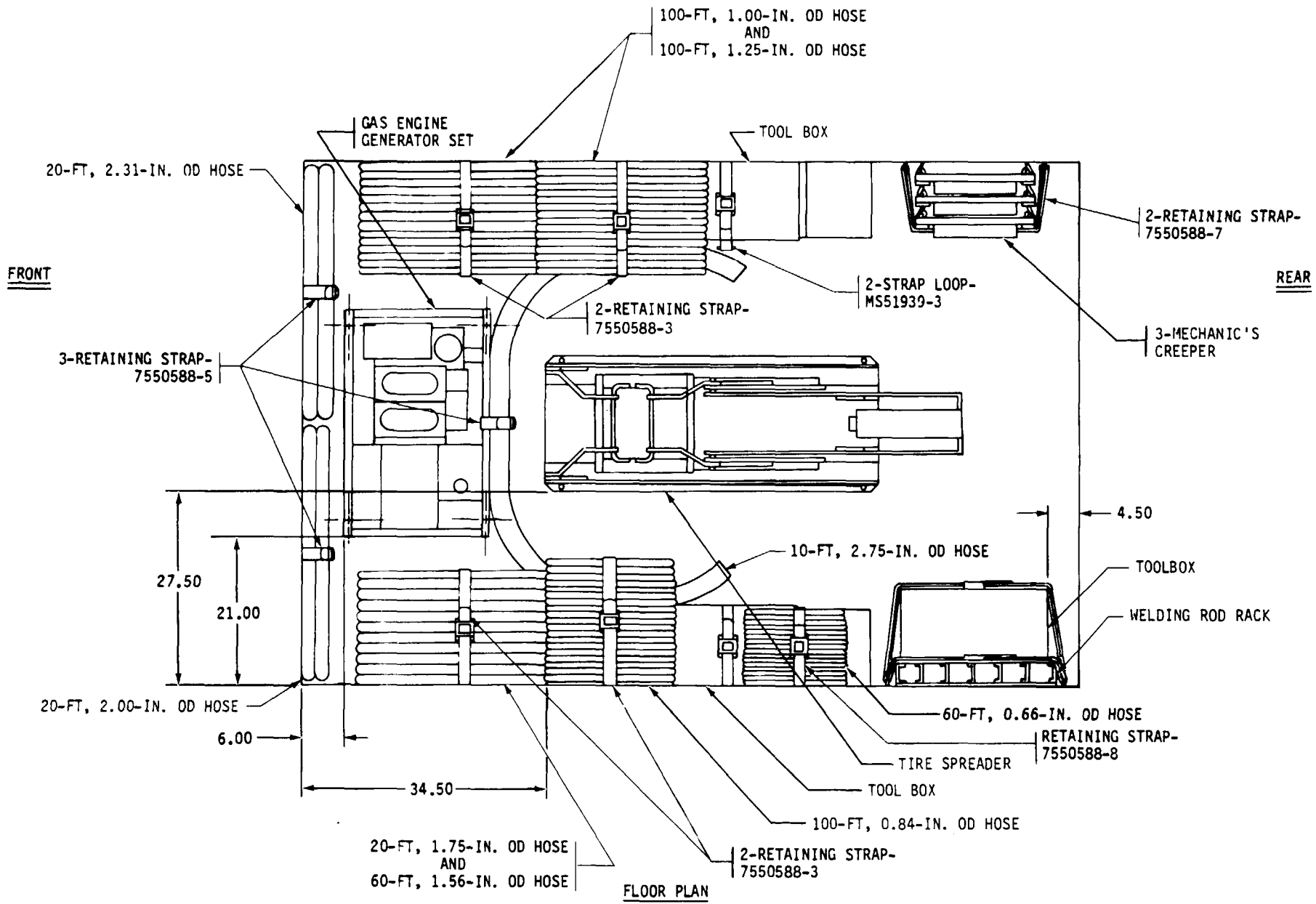

Figure 35. Components to be Mounted, Unit 6, M105A2, Floor Plan.

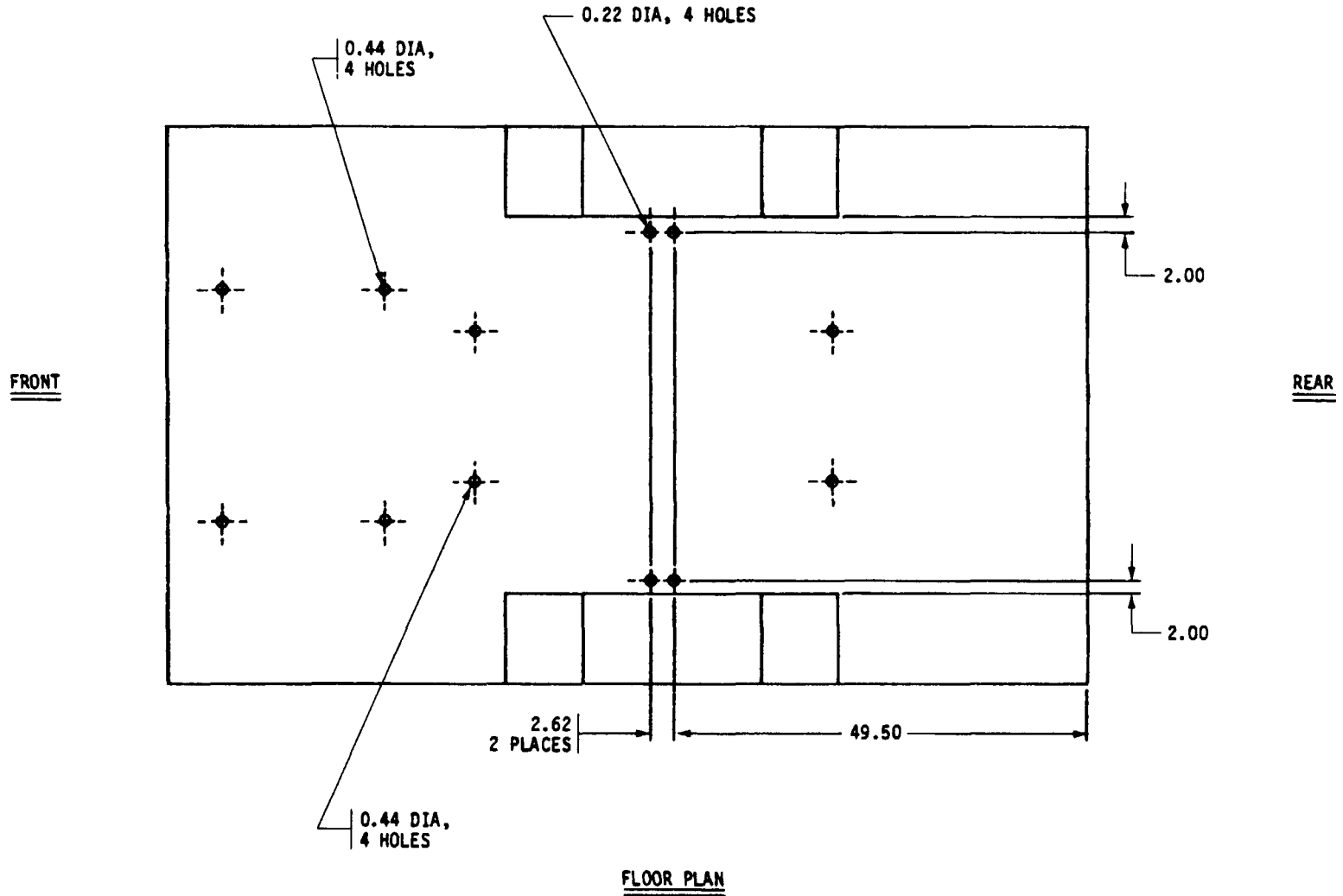

Figure 36. Hole Dimensions for Mounting Holes and Strap Loops, Unit 6, M105A2, Floor Plan.

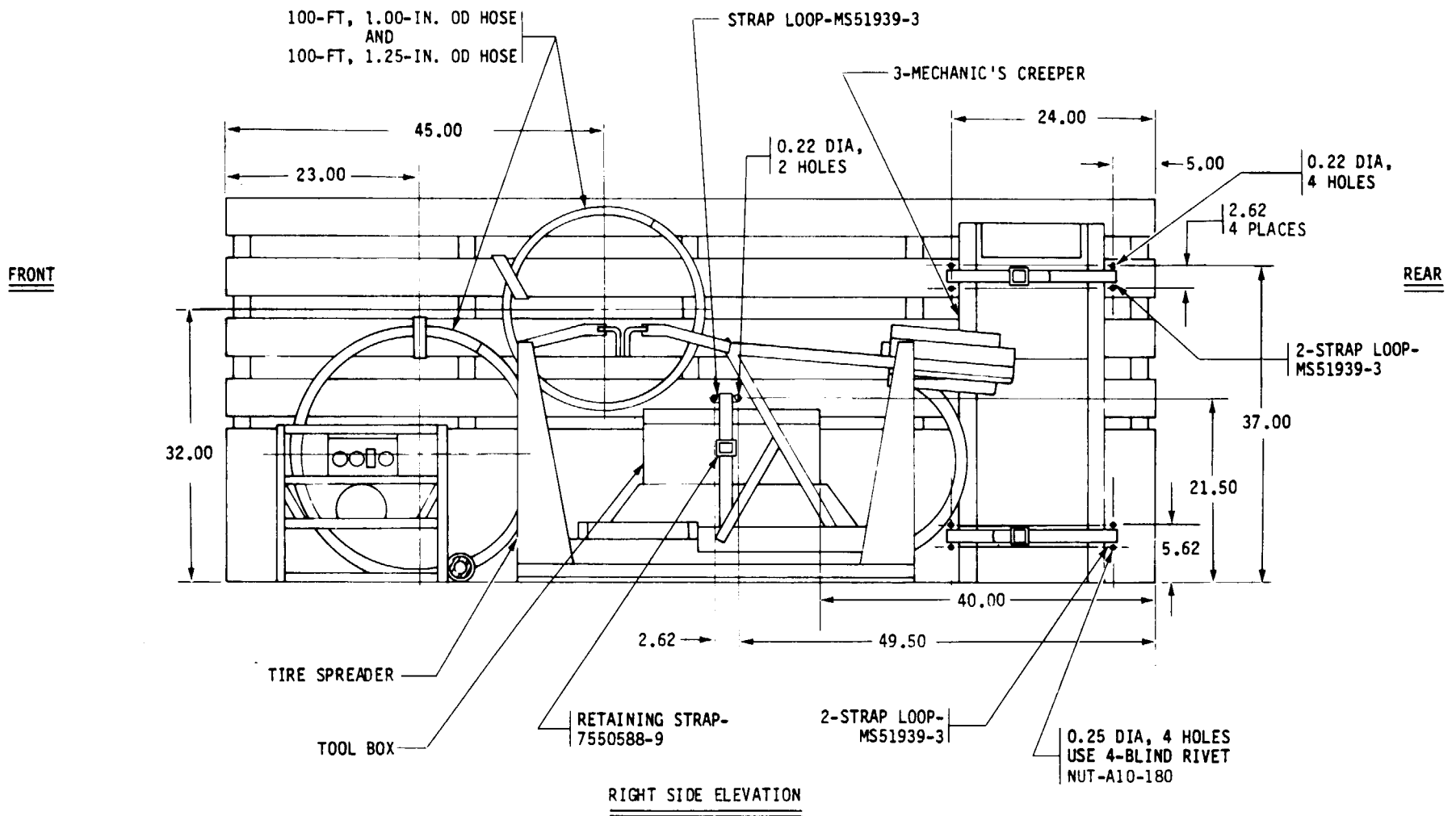

Figure 37. Hole Dimensions for Blind Rivet Nuts and Strap Loops, Unit 6, M105A2, Right Side Elevation.

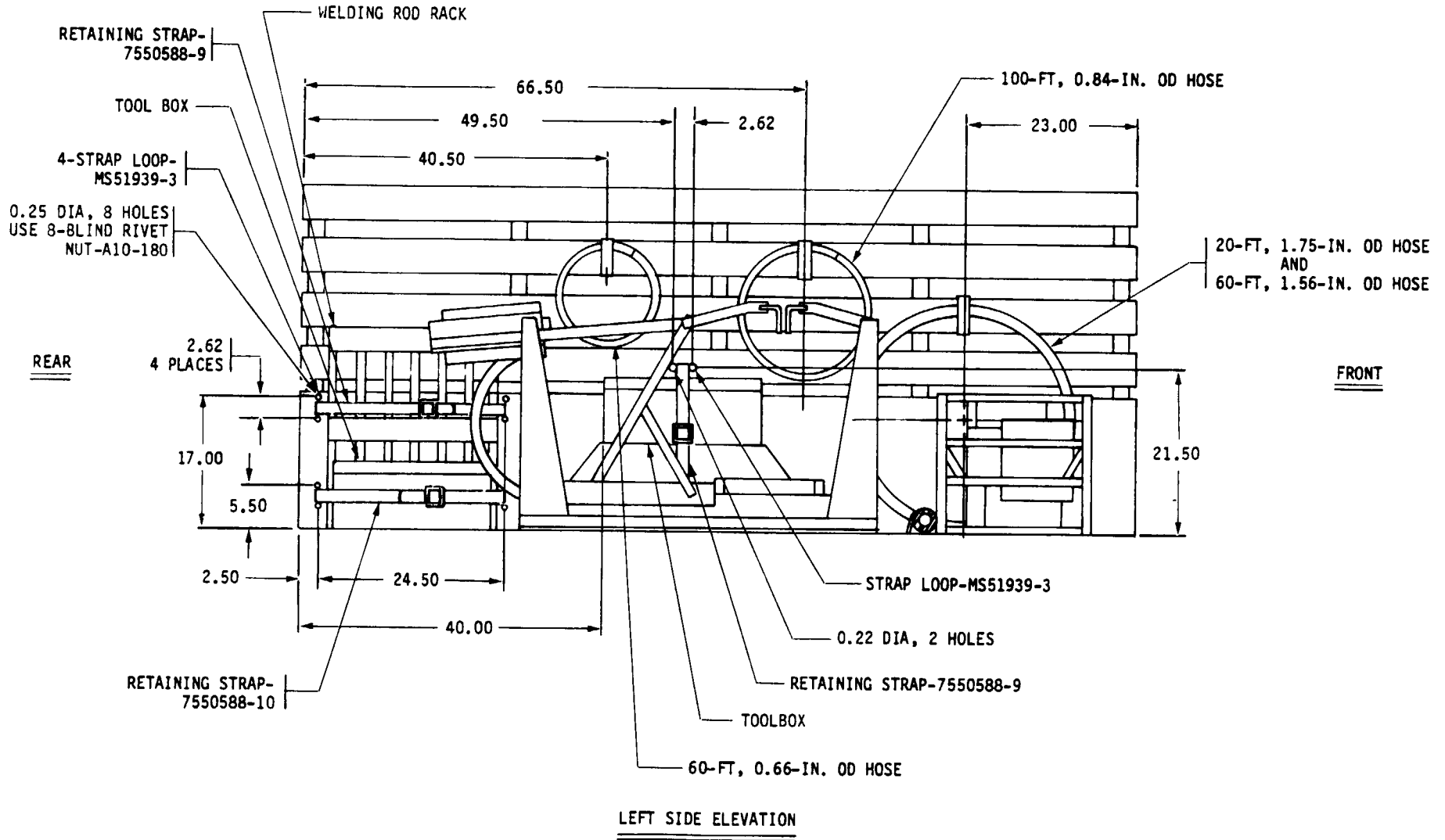
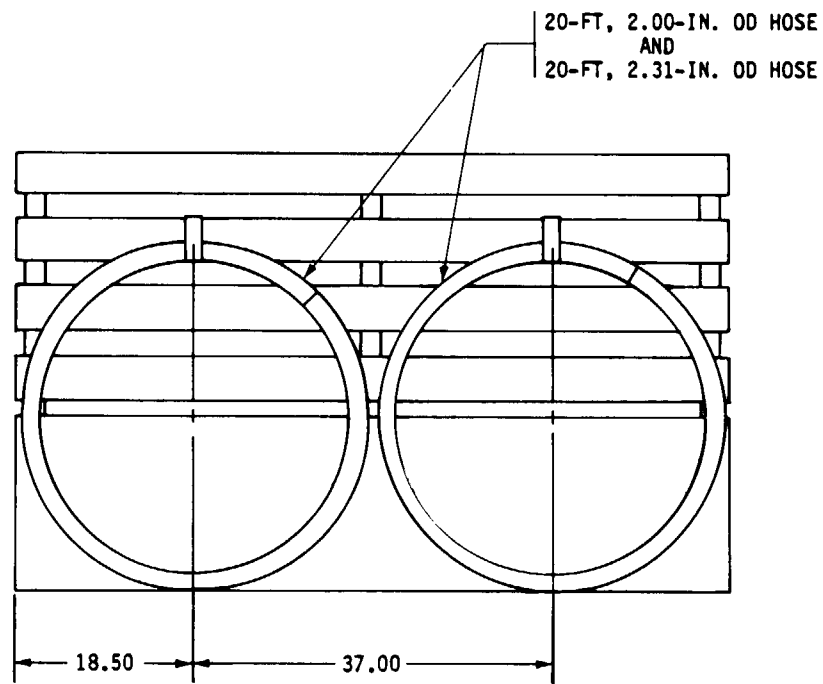

Figure 38. Hole Dimensions for Blind Rivet Nuts and Strap Loops, Unit 6, M105A2, Left Side Elevation.



FRONT ELEVATION

Figure 39. Retaining Strap Locations for Mounting 20-Ft Hoses, Unit 6, M105A2, Front Elevation.

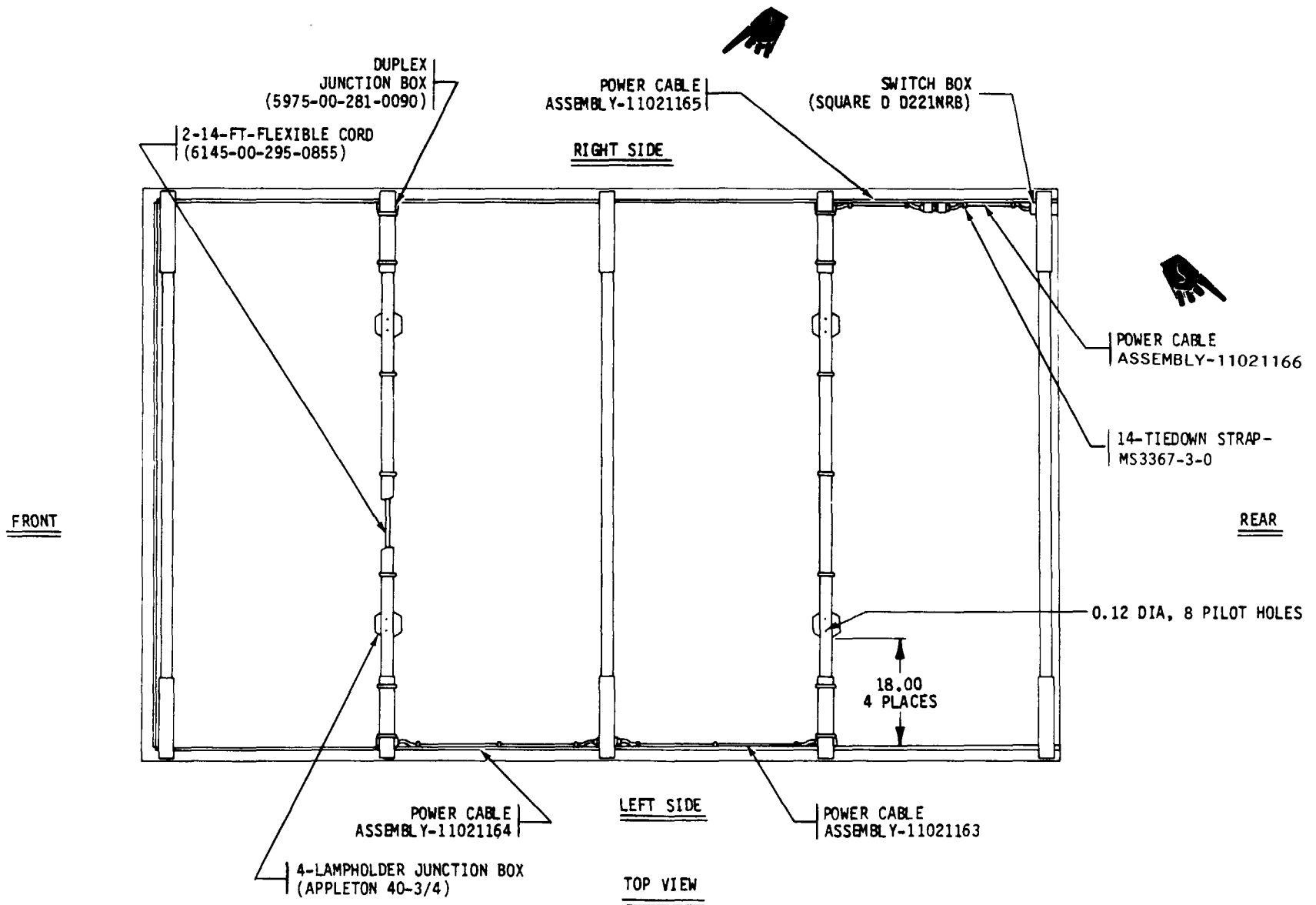

Figure 40. Electrical Components to be Mounted, Units 2 and 3, M35A2, Top View.

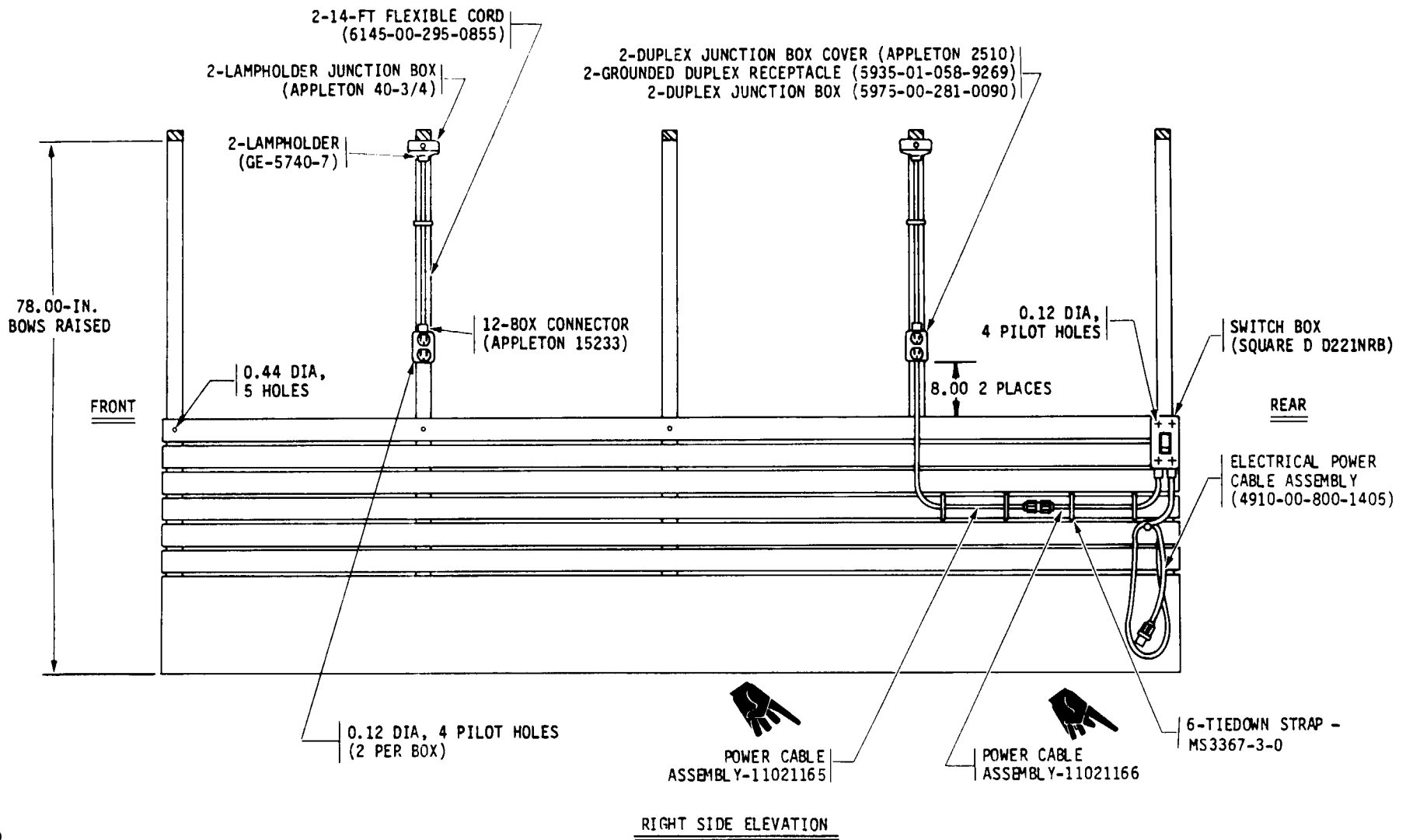

Figure 41. Electrical Components to be Mounted, Units 2 and 3, M35A2, Right Side Elevation.

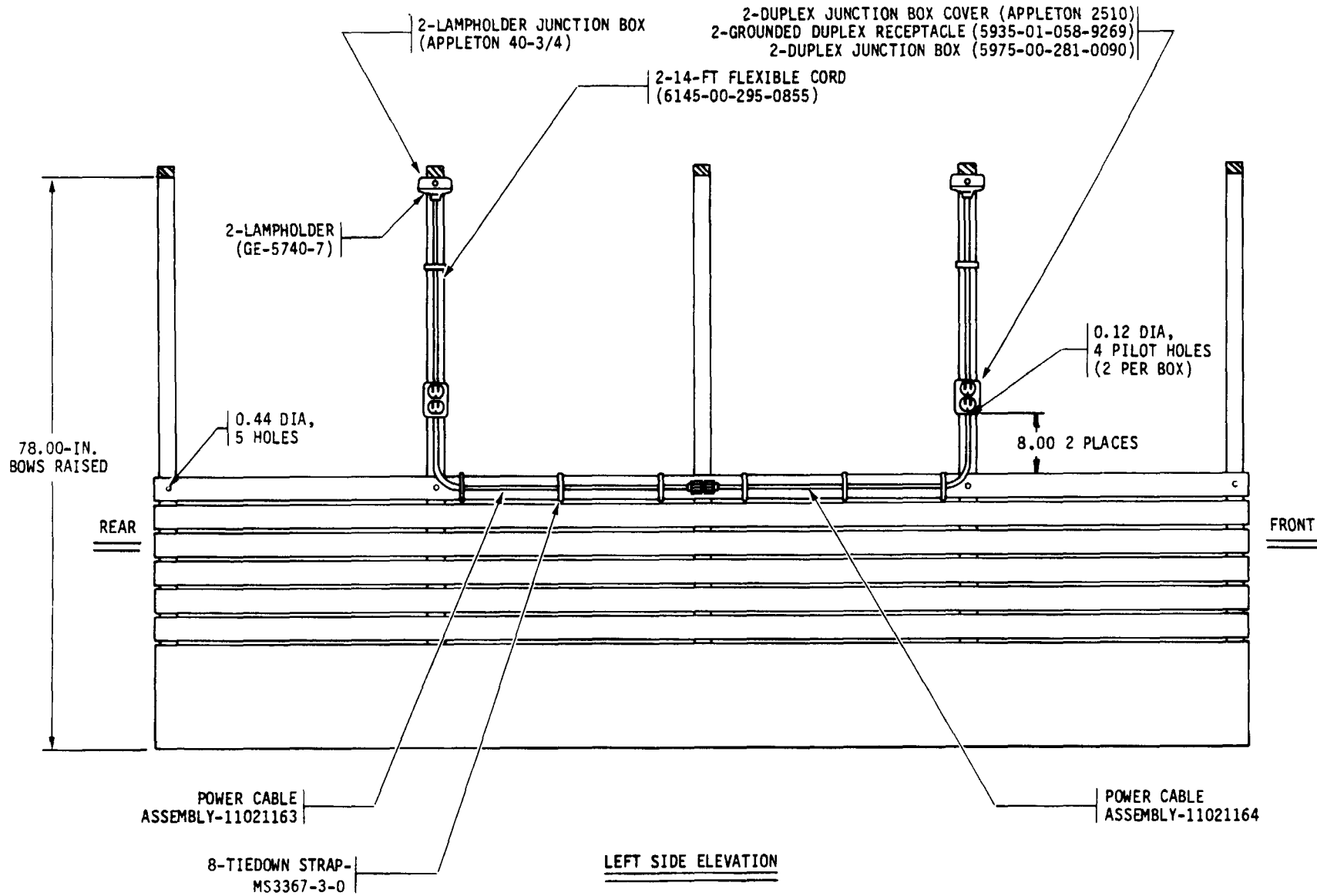

Figure 42. Electrical Components to be Mounted, Units 2 and 3, M35A2, Left Side Elevation.

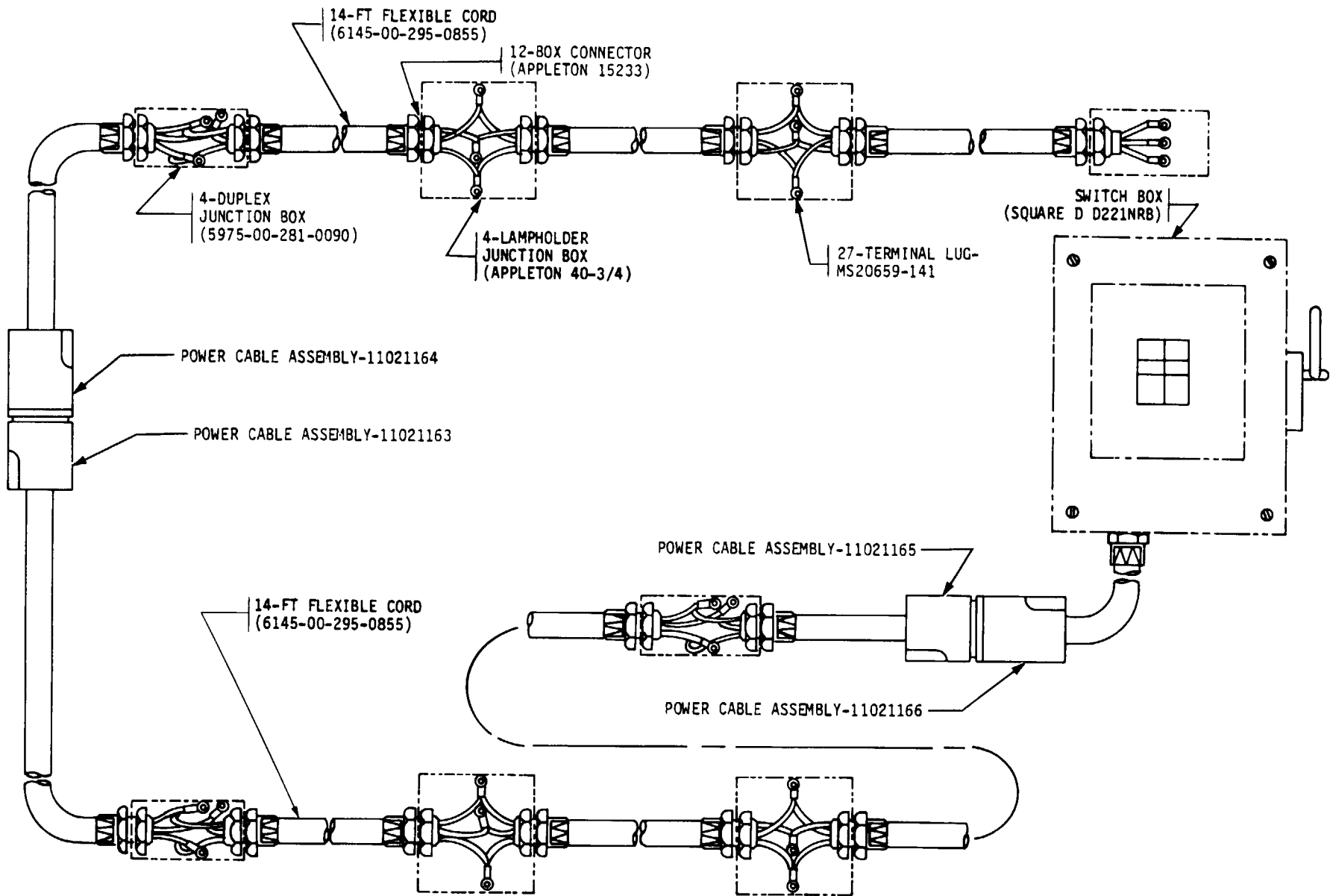

Figure 43. Electrical Schematic, Units 2 and 3, M35A2.

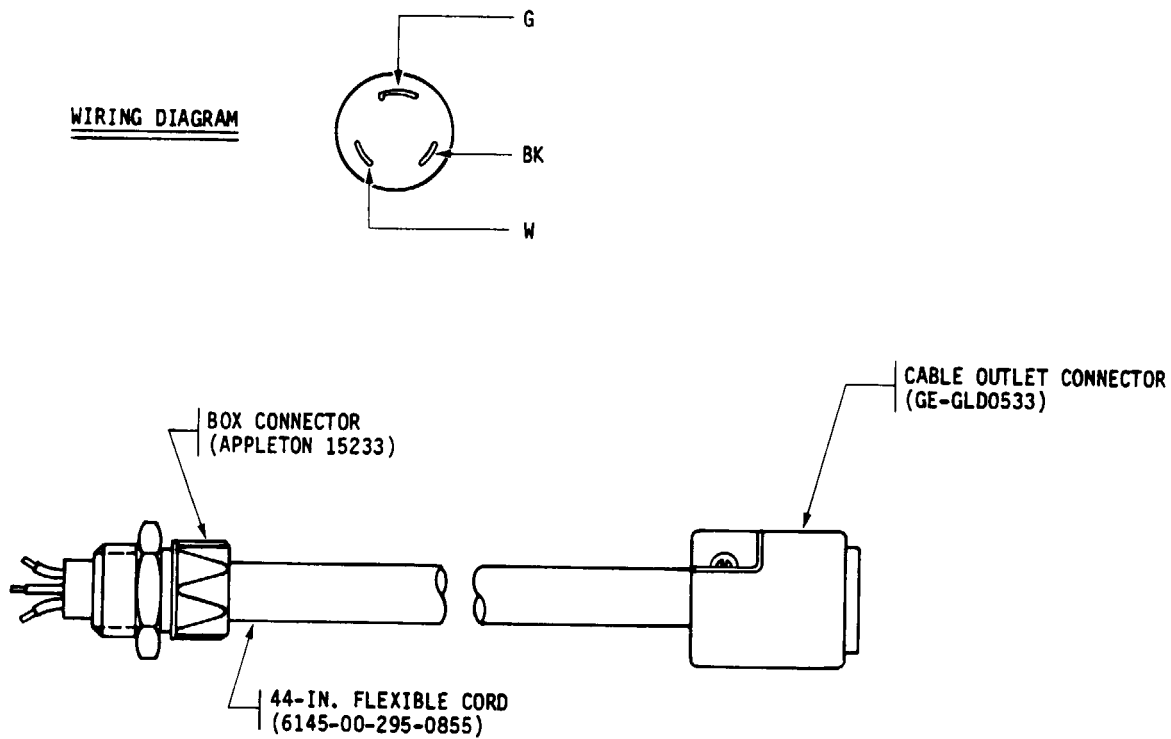

Figure 44. Power Cable Assembly, 11021163, Units 2 and 3, M35A2.

WIRING DIAGRAM

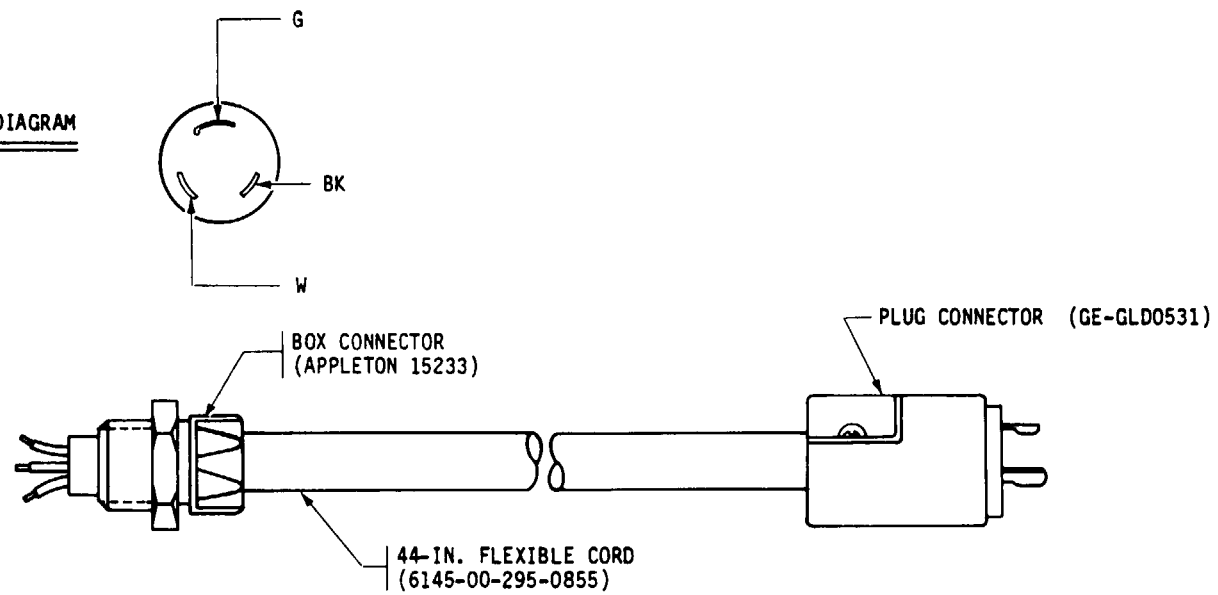

Figure 45. Power Cable Assembly, 11021164, Units 2 and 3, M35A2.

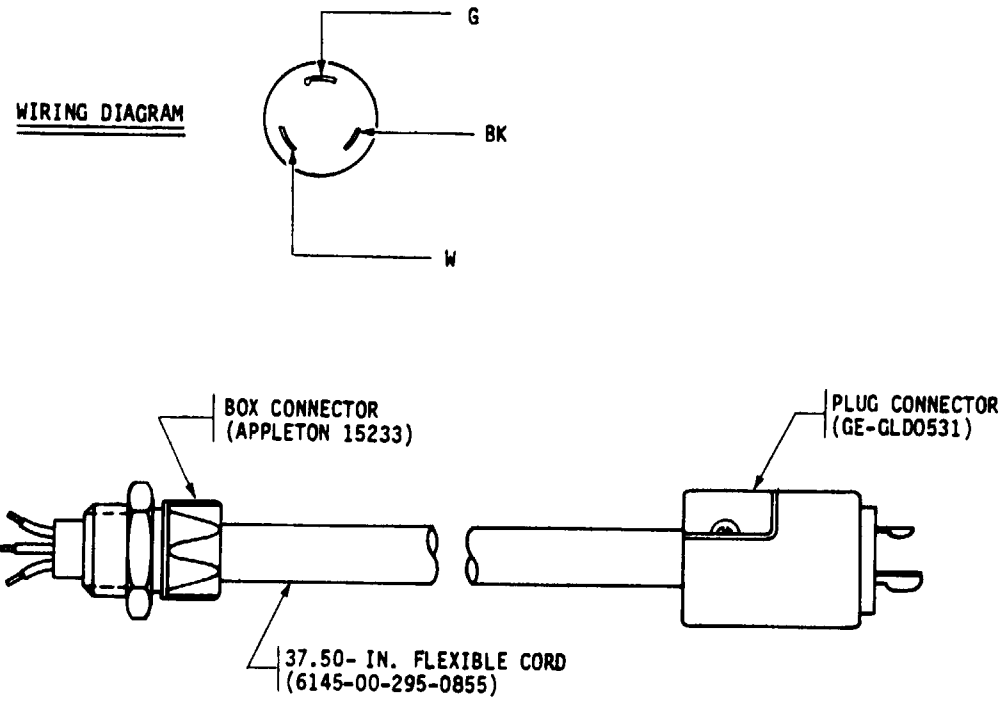

Figure 46. Power Cable Assembly, 11021165, Units 2 and 3, M35A2.

WIRING DIAGRAM

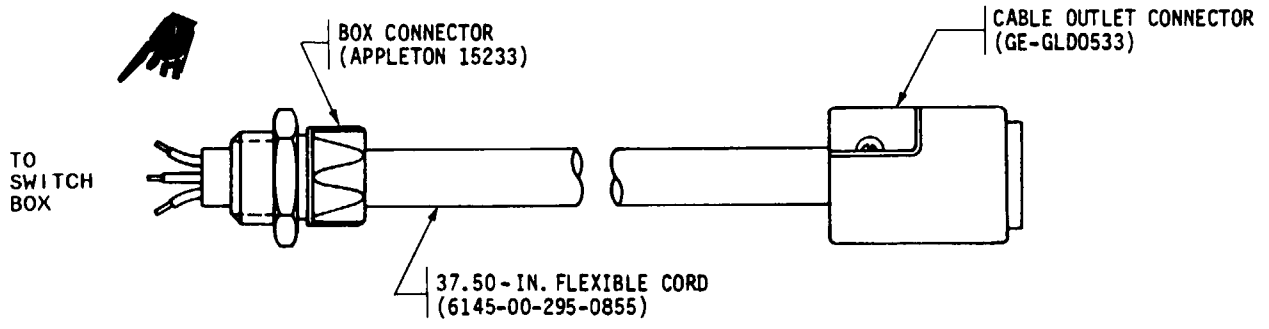
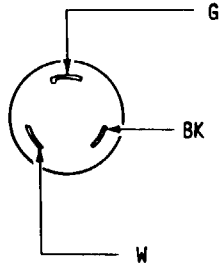

Figure 47. Power Cable Assembly, 11021166, Units 2 and 3, M35A2.

Table 4. Standard Conversion Chart

Nominal size	Decimal size	Nominal size	Decimal size
1/16	0.06	35/64	0.55
5/64	0.08	9/16	0.56
3/32	0.09	37/64	0.58
7/64	0.11	19/32	0.59
1/8	0.12	39/64	0.61
9/64	0.14	5/8	0.62
5/32	0.16	41/64	0.64
11/64	0.17	21/32	0.66
3/16	0.19	43/64	0.67
13/64	0.20	11/16	0.69
7/32	0.22	45/64	0.70
15/64	0.23	23/32	0.72
1/4	0.25	47/64	0.73
17/64	0.27	3/4	0.75
9/32	0.28	49/64	0.77
19/64	0.30	25/32	0.78
5/16	0.31	51/64	0.80
21/64	0.33	13/16	0.81
11/32	0.34	53/64	0.83
23/64	0.36	27/32	0.84
3/8	0.38	55/64	0.86
25/64	0.39	7/8	0.88
13/32	0.41	57/64	0.89
27/64	0.42	29/32	0.91
7/16	0.44	59/64	0.92
29/64	0.45	15/16	0.94
15/32	0.47	61/64	0.95
31/64	0.48	31/32	0.97
1/2	0.50	63/64	0.98
33/64	0.52	1	1.00
17/32	0.53		

By Order of the Secretary of the Army:

JOHN A. WICKHAM, JR.
General, United States Army
Chief of Staff

Official:

R. L. DILWORTH
Brigadier General, United States Army
The Adjutant General

DISTRIBUTION:

To be distributed in accordance with DA Form 12-21, Requirements for
FSC 4910: Motor Vehicle, Repair Shop Specialized Equipment.

RECOMMENDED CHANGES TO EQUIPMENT TECHNICAL PUBLICATIONS



THEN...JOT DOWN THE
DOPE ABOUT IT ON THIS FORM.
CAREFULLY TEAR IT OUT, FOLD IT
AND DROP IT IN THE MAIL.

SOMETHING WRONG WITH PUBLICATION

FROM: (PRINT YOUR UNIT'S COMPLETE ADDRESS)

DATE SENT

PUBLICATION NUMBER

PUBLICATION DATE

PUBLICATION TITLE

BE EXACT PIN-POINT WHERE IT IS

PAGE
NO.

PARA-
GRAPH

FIGURE
NO.

TABLE
NO.

IN THIS SPACE, TELL WHAT IS WRONG
AND WHAT SHOULD BE DONE ABOUT IT.

TEAR ALONG PERFORATED LINE

PRINTED NAME, GRADE OR TITLE AND TELEPHONE NUMBER

SIGN HERE

The Metric System and Equivalents

Linear Measure

1 centimeter = 10 millimeters = .39 inch
 1 decimeter = 10 centimeters = 3.94 inches
 1 meter = 10 decimeters = 39.37 inches
 1 dekameter = 10 meters = 32.8 feet
 1 hectometer = 10 dekameters = 328.08 feet
 1 kilometer = 10 hectometers = 3,280.8 feet

Weights

1 centigram = 10 milligrams = .15 grain
 1 decigram = 10 centigrams = 1.54 grains
 1 gram = 10 decigrams = .035 ounce
 1 dekagram = 10 grams = .35 ounce
 1 hectogram = 10 dekagrams = 3.52 ounces
 1 kilogram = 10 hectograms = 2.2 pounds
 1 quintal = 100 kilograms = 220.46 pounds
 1 metric ton = 10 quintals = 1.1 short tons

Liquid Measure

1 centiliter = 10 milliliters = .34 fl. ounce
 1 deciliter = 10 centiliters = 3.38 fl. ounces
 1 liter = 10 deciliters = 33.81 fl. ounces
 1 dekaliter = 10 liters = 2.64 gallons
 1 hectoliter = 10 dekaliters = 26.42 gallons
 1 kiloliter = 10 hectoliters = 264.18 gallons

Square Measure

1 sq. centimeter = 100 sq. millimeters = .155 sq. inch
 1 sq. decimeter = 100 sq. centimeters = 15.5 sq. inches
 1 sq. meter (centare) = 100 sq. decimeters = 10.76 sq. feet
 1 sq. dekameter (are) = 100 sq. meters = 1,076.4 sq. feet
 1 sq. hectometer (hectare) = 100 sq. dekameters = 2.47 acres
 1 sq. kilometer = 100 sq. hectometers = .386 sq. mile

Cubic Measure

1 cu. centimeter = 1000 cu. millimeters = .06 cu. inch
 1 cu. decimeter = 1000 cu. centimeters = 61.02 cu. inches
 1 cu. meter = 1000 cu. decimeters = 35.31 cu. feet

Approximate Conversion Factors

To change	To	Multiply by	To change	To	Multiply by
inches	centimeters	2.540	ounce-inches	newton-meters	.007062
feet	meters	.305	centimeters	inches	.394
yards	meters	.914	meters	feet	3.280
miles	kilometers	1.609	meters	yards	1.094
square inches	square centimeters	6.451	kilometers	miles	.621
square feet	square meters	.093	square centimeters	square inches	.155
square yards	square meters	.836	square meters	square feet	10.764
square miles	square kilometers	2.590	square meters	square yards	1.196
acres	square hectometers	.405	square kilometers	square miles	.386
cubic feet	cubic meters	.028	square hectometers	acres	2.471
cubic yards	cubic meters	.765	cubic meters	cubic feet	35.315
fluid ounces	milliliters	29.573	cubic meters	cubic yards	1.308
pints	liters	.473	milliliters	fluid ounces	.034
quarts	liters	.946	liters	pints	2.113
gallons	liters	3.785	liters	quarts	1.057
ounces	grams	28.349	liters	gallons	.264
pounds	kilograms	.454	grams	ounces	.035
short tons	metric tons	.907	kilograms	pounds	2.205
pound-feet	newton-meters	1.356	metric tons	short tons	1.102
pound-inches	newton-meters	.11296			

Temperature (Exact)

°F Fahrenheit temperature 5/9 (after subtracting 32) Celsius temperature °C

PIN: 061623-001